

# On the Orders of Measurement and Experiment

## On the Orders of Measurement and Experiment

Note:

- Lay out a philosophical framework
- State principles

Purpose:

A statement on the principles of scientific investigation, philosophy and logic.

- Why? If you don't have an objective standard and philosophical framework, how can you draw meaningful and logical conclusions?

Before we can discuss experiments and the interpretation of their results, let's set an objective standard for the process by which reality can be tested and conclusions can be drawn.

Once the objective standards, methodology and philosophical framework of interpretation has been laid out, we we'll go over the history of light and its relationship with ether, motion and mathematics.

---

# Process

The Scientific Method is not a formula, but rather a process with a number of sequential steps designed to create an explainable outcome that increases our knowledge base. This process is as follows:

## STEP 1. Make an OBSERVATION

gather and assimilate information about an event, phenomenon, process, or an exception to a previous observation, etc.

## STEP 2. Define the PROBLEM

ask questions about the observation that are relevant and testable. Define the null hypothesis to provide unbiased results.

## STEP 3: Form the HYPOTHESIS

create an explanation, or educated guess, for the observation that is testable and falsifiable.

## STEP 4: Conduct the EXPERIMENT

devise and perform an experiment to test the hypothesis.

## STEP 5: Derive a THEORY

create a statement based in the outcome of the experiment that explains the observation(s) and predicts the likelihood of future observations.

<https://extension.unr.edu/publication.aspx?PubID=4239>

Note:

IMPORTANT: What constitutes an experiment? Introducing independent and dependent variables.

Which scientific method is being applied and how? Using this 5 step process as the baseline for our Scientific Method, we'll move on to how we'll analyze the experiments themselves and their results.

The method by which will result reality and analyze the results

---

# Philosophical Realism

Note:

My Frame of Interpretation:

- Portraying reality accurately,
- avoiding idealization or romanticization for abstractions.
- Proof through logical deduction.

Through experiment and logic, you can get closer and closer to the truth.

How will you interpret the data, philosophically, logically, ideologically?

It's important to understand your biases. Everyone is biased for some reason or another.

What are YOUR ideological and philosophical biases?

---

Note:

- Alright, we're almost juiced up and ready to out interpreting the world.
- 2 more pieces of information.
- Concept of [first-order](#) and [second-order](#),

These terms apply to:

- experiments,
- effects,
- measurements,
- mathematical derivation

In addition to that, we'll look at first-order and second-order mathematical interpretations.

First-order experiment

First-order mathematical derivation

First-order effect

---

# First-Order & Second-Order (Experiment)

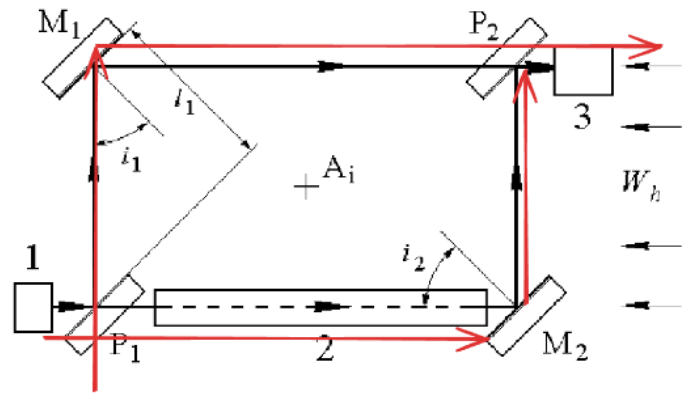
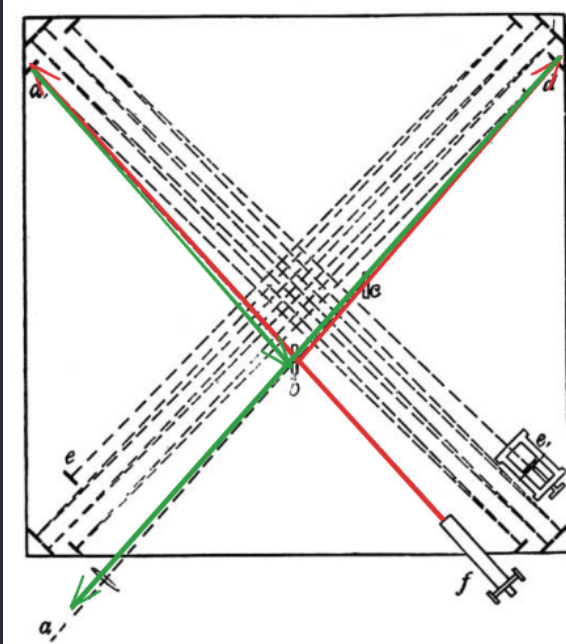

Note:

Since we'll be studying light and the travel thereof, let's say that any optical path that completes a circuit without round trip is a first-order measurement.

Good way to visualize this is looking at a topographical view of an orthogonal interferometry and a closed loop path.

Analogies:

**First-Order Experiment (One-way Measurement):**

- In a first-order experiment, you stand at the starting point, wait for the car to pass you, and use your stopwatch to measure the time it takes for the car to travel from the starting point to a designated point ahead.
- This is like observing the light from a distant star reaching us—measuring the time it takes for the light to travel from the star to us in a one-way journey.

**Second-Order Experiment (Two-way Measurement):**

- In a second-order experiment, measuring a car completing a there-and-back route
- assuming the car went the same speed in both directions

---

First-Order & Second-Order (Effect)

# First-Order Reactions

## Introduction

A first-order reaction is one in which the rate of reaction is proportional to the concentration of the reactant. To put it another way, doubling the concentration doubles the reaction rate. A first-order reaction can have one or two reactants, as in the case of the decomposition reaction.

## Table of Content

- [What is a First-Order Reaction?](#)
  - [Examples of First-Order Reactions](#)
- [Differential Rate Law for a First-Order Reaction](#)
- [Integrated Rate Law for a First-Order Reaction](#)
- [Graphical Representation of a First-Order Reaction](#)
- [Half-Life of a First-Order Reaction](#)
- [Frequently Asked Questions – FAQs](#)

## What is a First-Order Reaction?

A first-order reaction can be defined as a chemical reaction in which the reaction rate is linearly dependent on the concentration of only one reactant. In other words, a first-order reaction is a chemical reaction in which the rate varies based on the changes in the concentration of only one of the reactants. Thus, the order of these reactions is equal to 1.

Note:

Read highlighted. Summary a First-order effect is when you can trace back a proportional ratio with the cause of the measurement.

In the case of interferometry, directionality and motion will be measuring first-order velocity change in the induction rate of electromagnetic propagation.

---

# First-Order & Second-Order (Mathematics)

# $v/c$ or $v/c^2$

Note:

Recalling to the car analogy earlier.

Suppose in that situation you describe the velocity relationship with the car as  $v/c$ .

However, what if there is another effect present that is unnoticed by the  $v/c$  ratio.

If you needed to increase the precision analysis of the measurement, you could squared the denominator,  $c$  to analyze the relationship at a higher-order.

In theory, by moving the decimal place back, you're increasing your insight into the first-order measurement and from that ratio, you can deducing the components within the first-order effect that was measured.

This will become important later because a second-order effect cannot be used to explain the entirety of a first-order measurement.

In the Relativistic framework, we'll see first-order effects and measurements ignored by second-order abstractions. Particularly in the form of Lorentz transformations.

It's also important to note that there's nothing wrong with second-order mathematical to analyze a first-order measurement of a first-order effect, it's when you get lost in the abstraction in the second-order description and build an entire mythology around that analysis.

The significant distinction here is realizing relationship with the equations used in the measurements and if those relate to reality.



Note: 2:49

---

# Newton's Bucket 1687

Lab frame

Prediction

$$F_c = mv^2/r$$

Result



$$V > 0$$

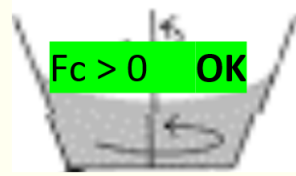

Bucket frame



$$V = 0$$

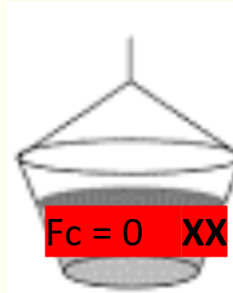

## Fictitious Forces!

Lab frame



Result

$$V > 0$$

Prediction

$$F_c = mv^2/r$$



$$F_c > 0 \quad \text{OK}$$

Bucket frame



$$V = 0$$



$$F_c = 0 \quad \text{XX}$$

**Not inertial,  
So add  
 $F_c = mv^2/r$  !!**

# Mach's principle 1883

Mainstream:

“physical law relating motion of distant stars to local inertial frame.”

“local laws determined by the large-scale structure of the universe.”



Ernst Mach

*such forces are produced by the relative rotation with respect to the Earth and the other celestial objects.*



Earth?....Yes stars? .....No

Newton: Absolute ref frame!....but where?

# Bennett's Hiker 2018

Hitchhiker frame

Car/Driver frame



Prediction:

$$F_d = M_d \cdot a$$

Driver feels inertial force  $F_d$   
✓

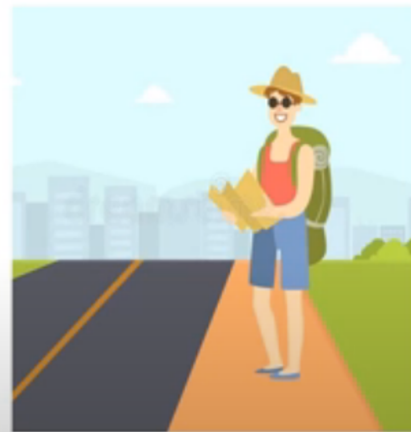

Prediction:

$$F_h = m_h(-a)$$

$$F_h \neq 0$$

But.... hiker feels no force!  
X

Note: Question: Where do the laws of physics apply?

Centripetal force  $F_c = mv^2/r$

Lab Frame:  $F_c > 0$  OK

When applying the velocity of the water wrt the lab frame, you're able to make the correct prediction mathematically.

Bucket Frame:  $F_c = 0$  XX

Bucket Observer inside the bucket sees stationary water with the lab frame spinning around him. He predicts a water velocity of 0. the Bucket Observer is unable to apply the laws of physics successfully to make a prediction.

Bennett's Hiker applies to linear motion



## A. What is the rest frame?

1. It is not the bucket
2. It is not the room, Earth, or Sun
3. Is it all the stars, galaxies, & matter?  
(The Machian theory)
4. Is it Space? (Newton's Theory)  
Or, space-time?

## (More detail on Hiker)

Is a satellite orbiting the Earth or is the [Earth](#) orbiting the satellite?

When speaking of orbits, you can apply this exact same thing to that. The Earth is NEVER orbiting the [satellite](#)

**Earth is the only frame that can predict the orbit of a satellite. The earth is the [lab frame](#).**

---

## Kinematics

- Measurements of motion
- No concern for casual force of motion

## DYNAMICS

- Future predictions of motion based on real forces
- Falsifies or supports hypothesized casual mechanism of the observed motion

Note:

[Kinematics](#) cannot distinguish relative motion, [DYNAMICS](#) can.

---

Proof by logical deduction

If an antecedent for gas pressure is a containment, it logically follows there must be a container.

---

The laws of physics ([Newton's equations of motion](#)) that hold true to this day, were derived in the [lab frame](#) (stationary, non-rotating) on Earth. All [non-inertial](#) frames, (coordinate systems) must invoke fake-forces to be [covariant](#) with the lab frame.

Logical deduction: The lab frame (stationary, non-rotating) is the preferred frame of reference to interpret reality.

Note: All experiments and dynamic predictions are done on Earth. Miraculously, the Earth is always just locally inertial enough accurately be the baseline for all of physics.

---

Bennet Slide

Note:

If we accept the logical deduction that [DYNAMICS](#) applies real forces in a system to make predictions, that in reality can confirm or falsify a hypothesis, then we accept the lab frame as true.

If we accept the lab frame, then Earth's motion is a hypothesis awaiting to be experimentally verified

Note: Insert slide of Euler's and Lagrange's equations from Bennett; review Bennett explanation

---

Note:

Now that we a framework of scientific and logic interpretation, let's go over the history of the hypothesis of Earth's motion and the ether.

---

Quick history on the aether; frame and [atomism](#) (insert Austin slide)

Note: false dichotomy, happy to hear another alternative, just let me know what it is

---

Note: Our analysis begins at the beginning of the study of light

Note: Roger Bacon (1219 - 1294) - Notice a light ray split by a glass of water produced different colors upon exiting the glass. This is the first alleged documentation someone noting light being split into wavelengths

---



Note: Newton splitting a beam of light with a prism.

---

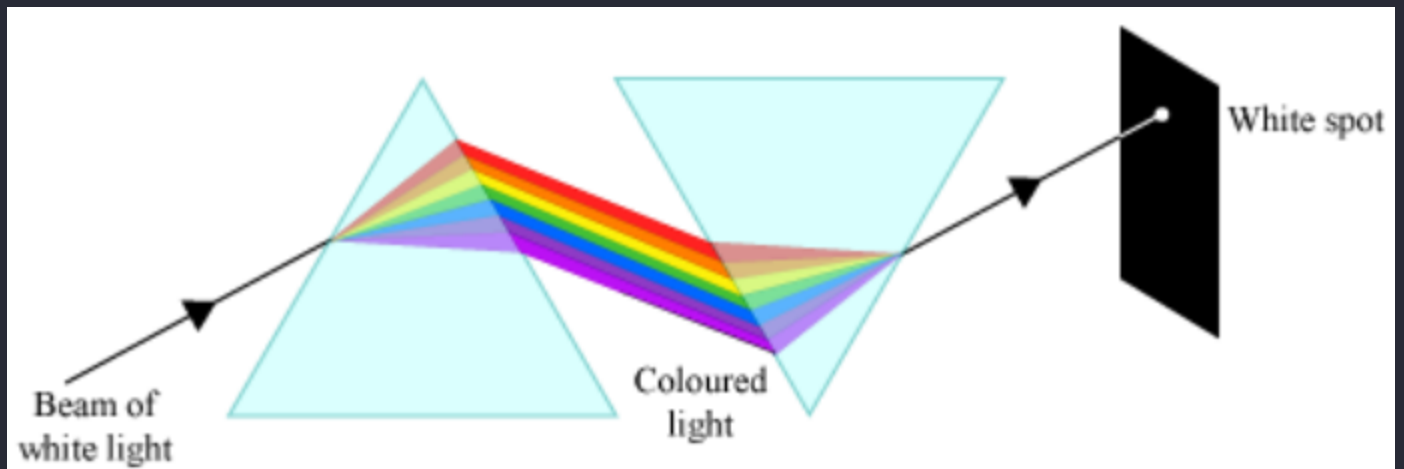
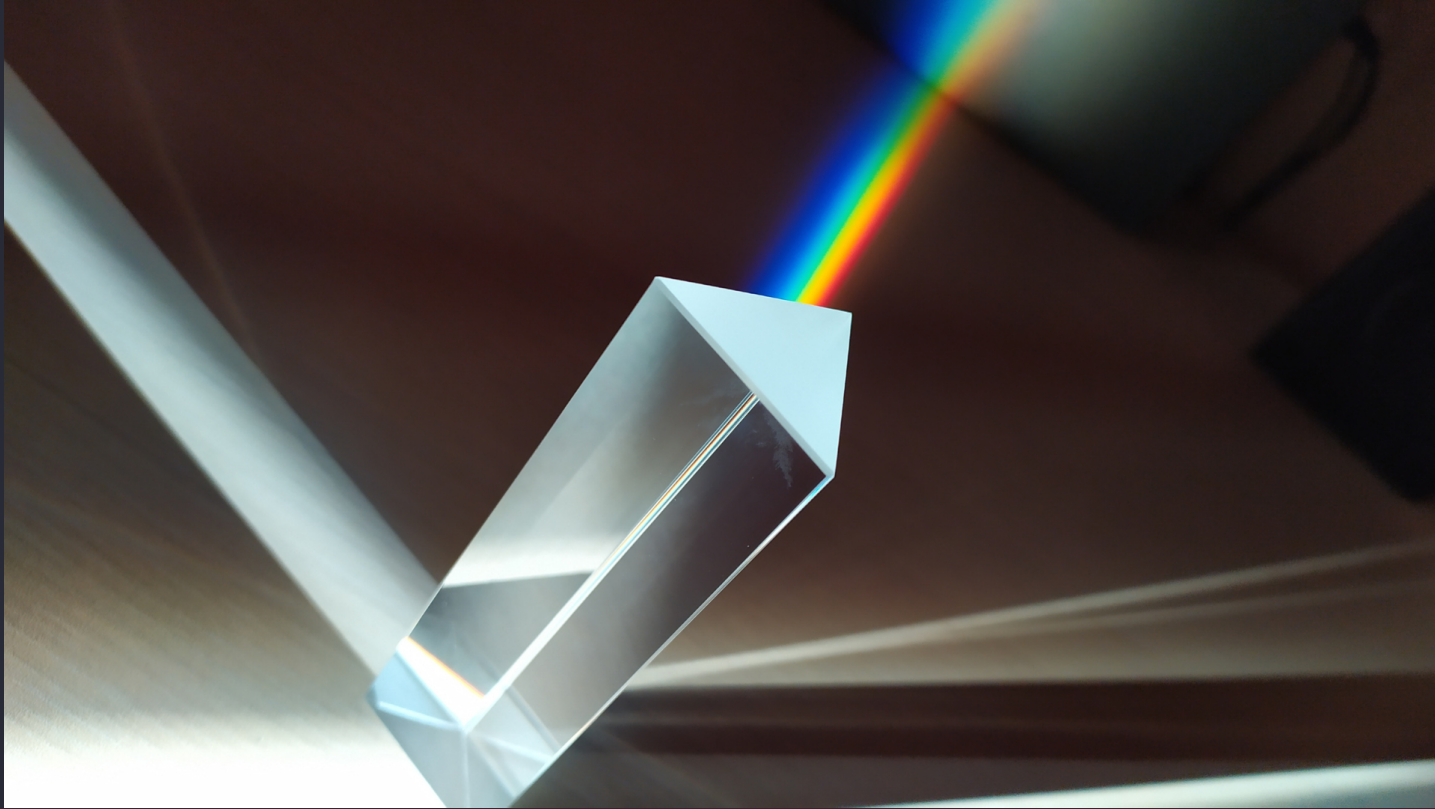

Note:

Newton set up a prism near his window, and projected a beautiful spectrum 22 feet onto the far wall. Further, to prove that the prism was not coloring the light, he **refracted the light back together**. Artists were fascinated by Newton's clear demonstration that light alone was responsible for color.

First-order effect; coherent light beams can be split into a spectrum of colors



Note: Joseph von [Fraunhofer](#) 1787 - 1826

---

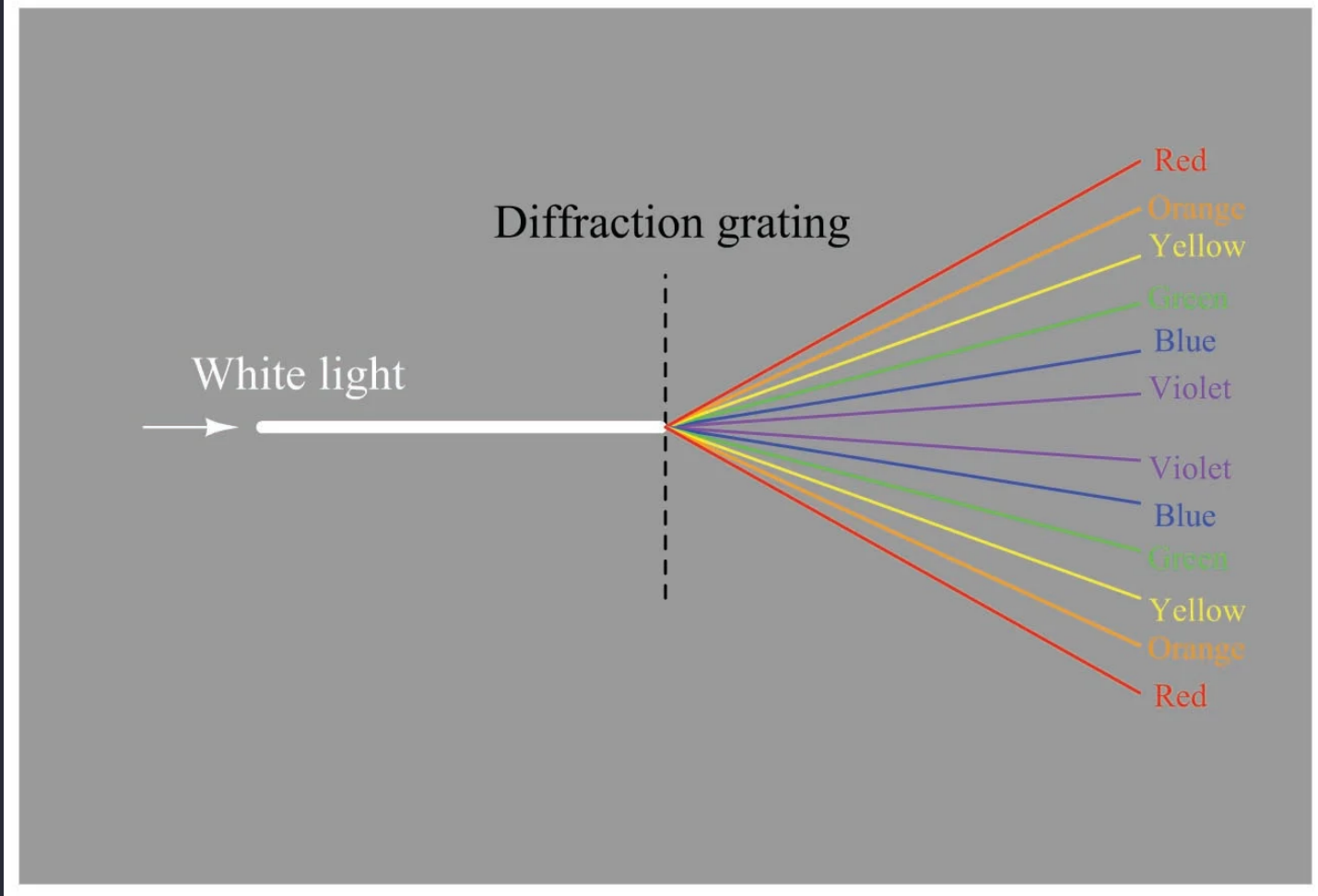

Note:

Similar setup to a prism, [Fraunhofer](#) used a diffraction grating to split a beam of light into wavelengths. He took it a step further and analyzed these wavelengths.

He categorized different light sources by the wavelengths they produced.

---

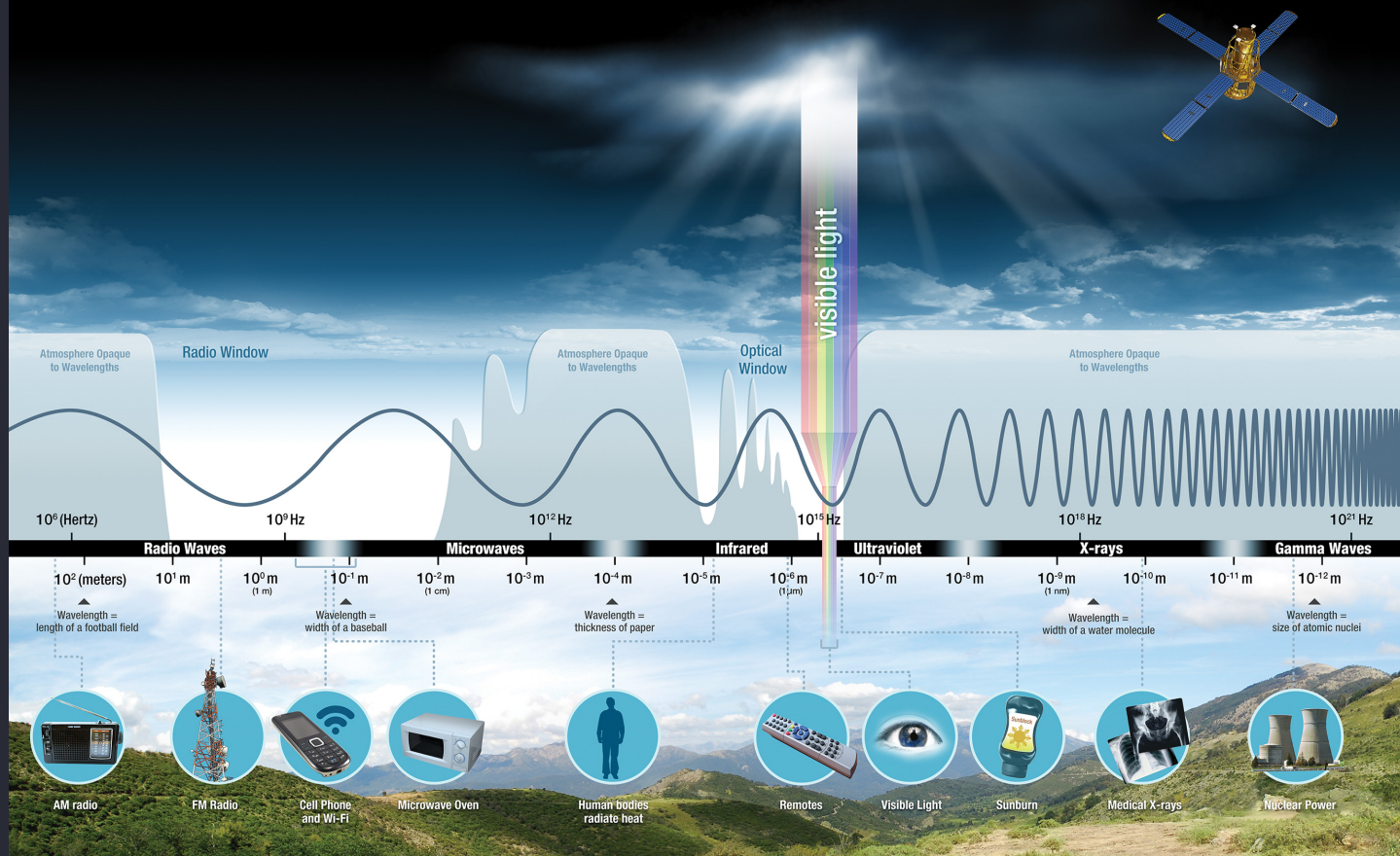

Note:

It wasn't just those 3 men mentioned before who completed the work, that was just an introduction to the process of it. Continuing the works and building upon that library of wavelengths, colors and temperatures, etc, we have

Heinrich Hertz, 1885

Wilhelm Conrad Rontgen, 1895, X-rays, current passes through a bulb with low air pressure

Becquerel, Curie, Paul Villard and Ernest Rutherford working in the radiation sector (invisible wavelengths) [y.rays](#)

### Wavelengths

1. *Light sources producing light; sunlight, starlight, fire, incandescent lamps, electricity, etc*
2. *When a coherent beam of light hits a prism, the beam is split into 7 colors; Red, Orange, Yellow, Green, Blue, Indigo, Violet*
3. *When the split spectrum is recombined, the*

*beam returns to its original color*

#### 4. *Wavelengths and the colors correspond to a measurement in meters (nm, mm, etc) of the wavelength itself*

Notes:

Recap:

Obs'd. Phenom.: Light beams split into multiple colors

Problem/Question: Is color inside the beam or is the prism adding color to the beam?

Hypo: The prism does not color the beam

Experiment: Use another prism to recombine the beam and see if the color remains

IV: Prism(s), for splitting and recombining

DV: The beam of light

Result: Adding a second prism shows that when the beam is recombined, there split visible spectrum of colors returns to the the original beam color.

Conclusion: A second prism returns the split beam into its original spectral composition. The results support the hypothesis that a prism does not introduce new chromatic elements into the beam.

Let's now go over the history of Frequency measurements; Fizeau (1849) and Maxwell (1865), et al.

---



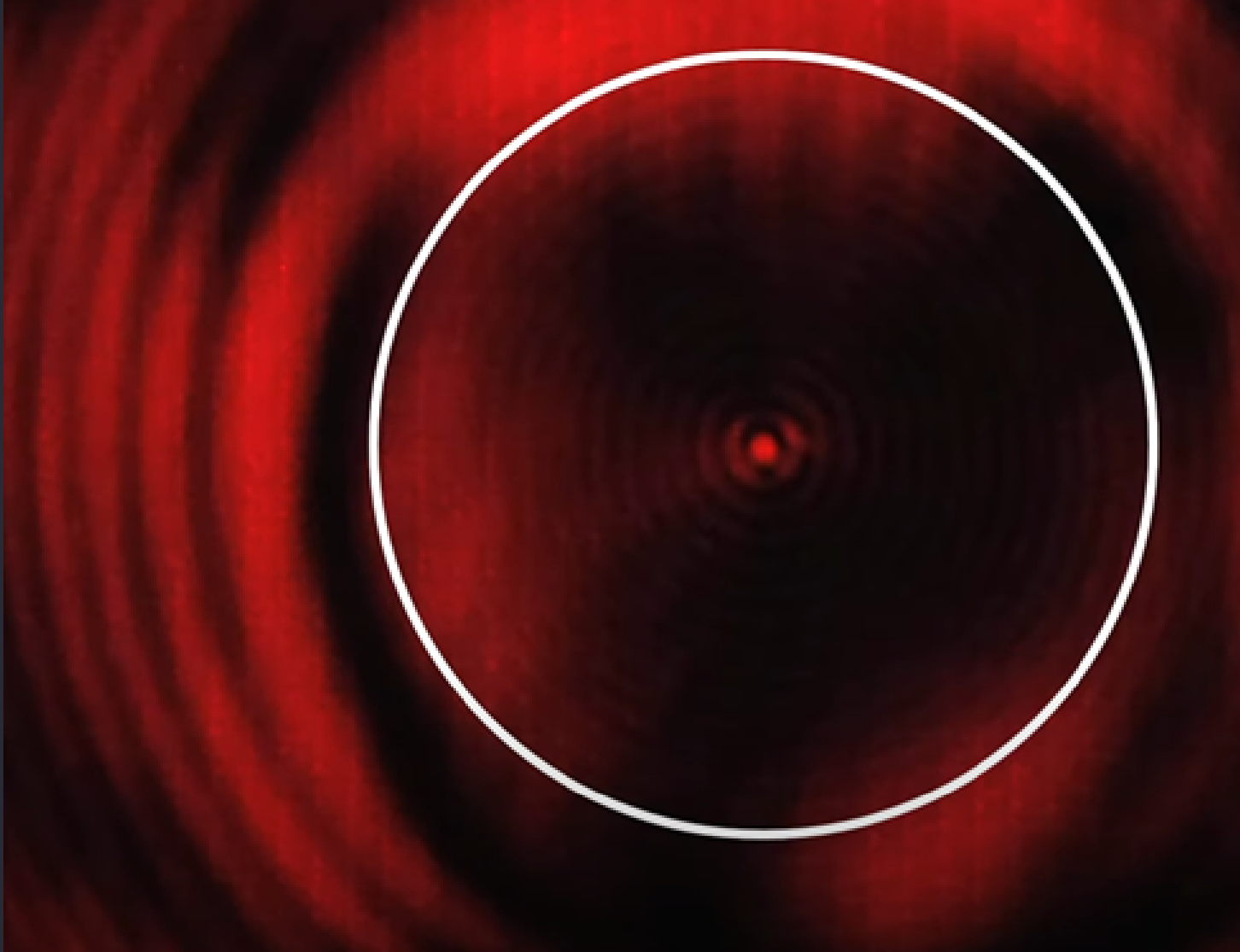

Note: As move from measuring the wavelength of light, we'll look at the Arago effect or "[Arago spot](#)".

When a coherent beam of light is diffracted by a sphere, the waves will recombined as they pass the obstruction and their intersection will produce a dot directly behind the spherical obstruction. Radially outward from the intersection point, you'll see a fringe pattern in the form of concentric circles.

The experimental results shown here explain why Arago was a proponent of wave theory. Light as a corpuscle could not recombine after being directly obstructed.

Obs'd Phenom: Light producing diffraction patterns

Problem/Question: If light produces a diffraction pattern and recombines behind objects, how can it be a particle?

Hypo: A sphere placed in the center of a coherent beam will diffract around the sphere and recombine such that it makes an interference pattern with an illuminated dot in the center due to the waves intersecting on the recombine.

Experiment: Coherent beam, sphere, wall

Result: illuminated dot directly behind the sphere

Conclusion: Light is a wave because it behaves like one

---

$$c = \lambda \cdot f$$

Note:

Recap

- $\lambda$  = Wavelength = the distance between successive peaks (or troughs) of a wave. (measured in meters, nm, etc)
- $f$  = Frequency = directly proportional to the SoL; number of cycles (oscillations) per second (measured in Hz)

$\lambda$  and  $f$  share an inversely proportional relationship, as the wavelength increases, the frequency decreases and vice versa.

Now let's get into the freq. measurements. We'll pick it back up with Arago again

---

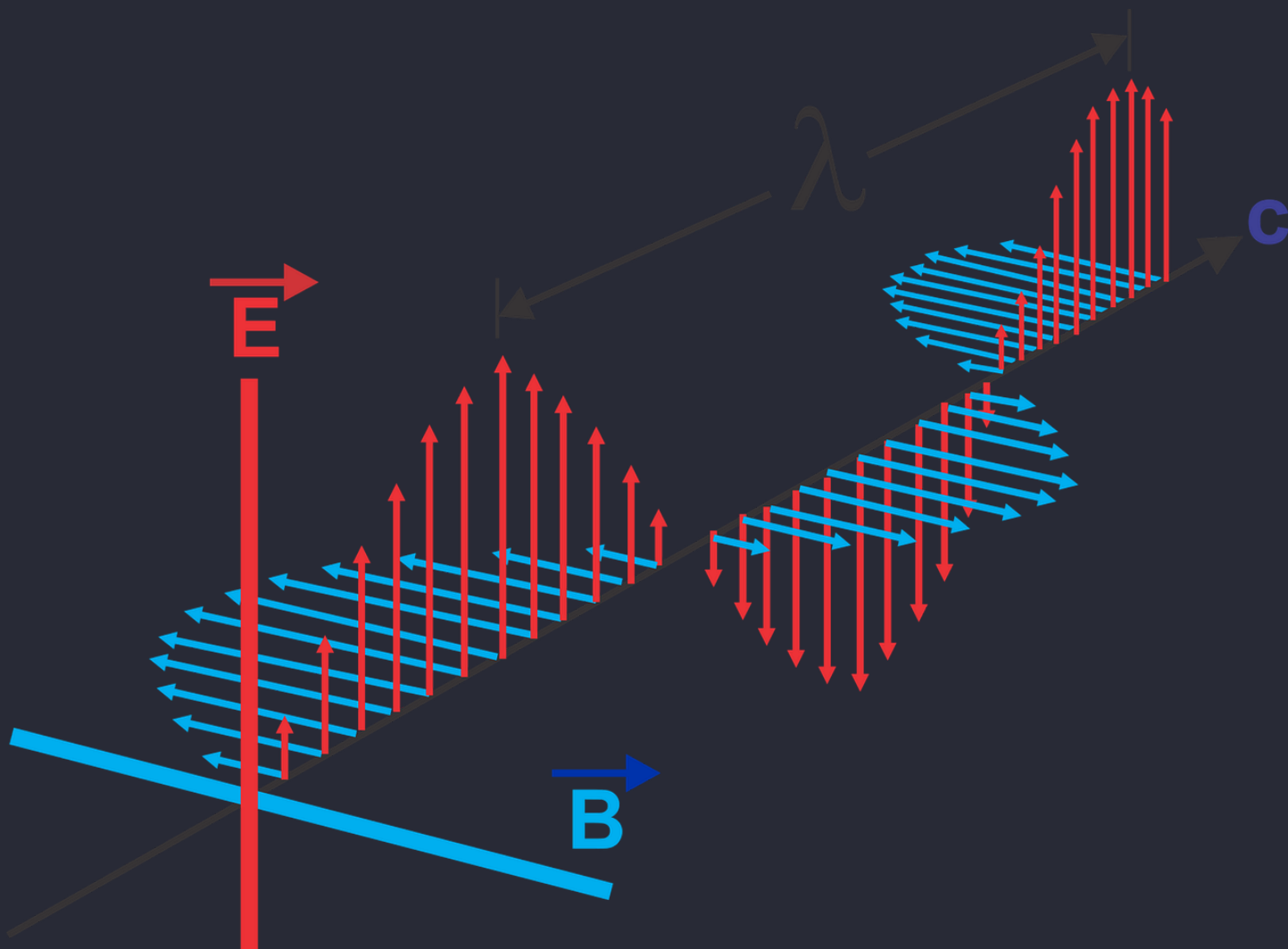

Note:

Recap

- $\lambda$  = Wavelength = the distance between successive peaks (or troughs) of a wave. (measured in meters, nm, etc)
- $f$  = Frequency = directly proportional to the SoL; number of cycles (oscillations) per second (measured in Hz)

$\lambda$  and  $f$  share an inversely proportional relationship, as the wavelength increases, the frequency decreases and vice versa.

Now let's get into the freq. measurements. We'll pick it back up with Arago again



Note: Arago, famous for two things;

1. Discovered that the focal length of a telescope did not need to be adjusted based on the assumption that if the Earth were in motion, you would have to adjust the focal length of the telescope when viewing stars in the alleged direction of motion and against

The stars are so far, the relative motion of the Earth between them is negligible

# The Earth doesn't move

"...Arago covered half of his telescope with an achromatic prism. He found that the aberration angle was independent of whether light passed through the prism..." -Arthur Miller

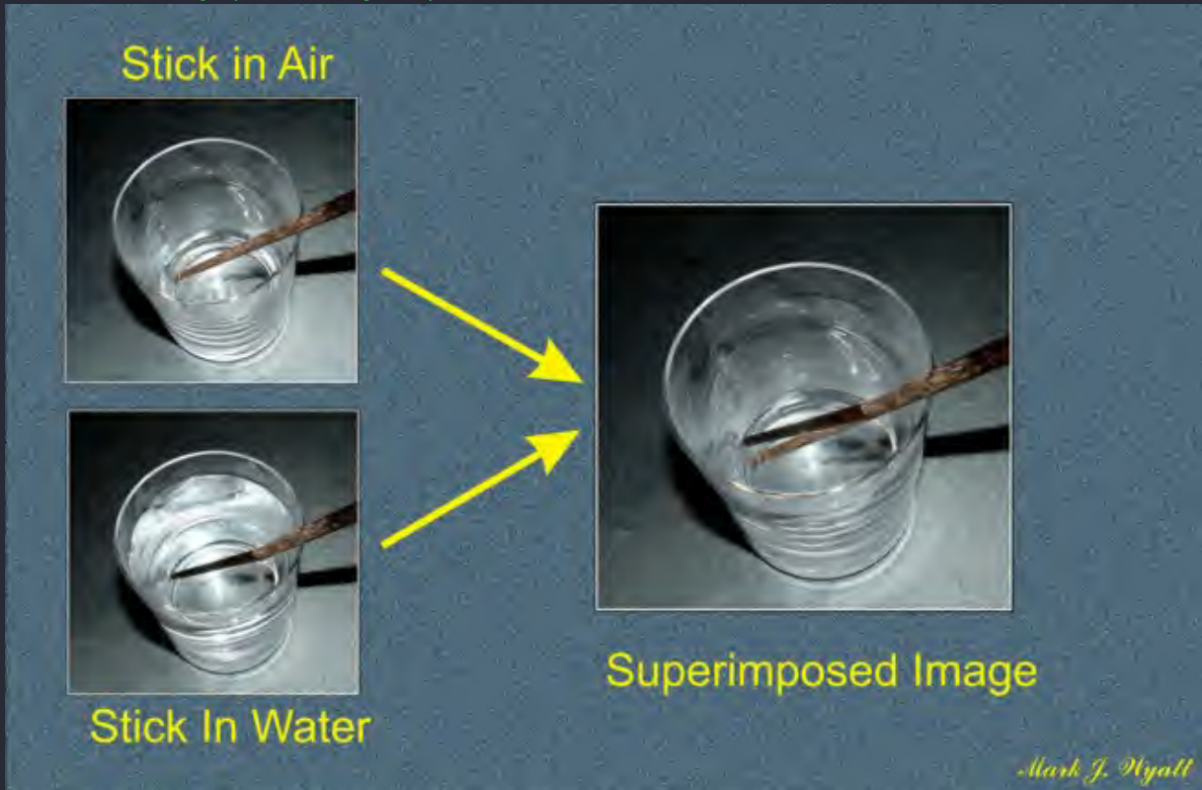

Note:

*"In another experiment, Arago, showed that whether the light beam going through the glass was pointed in the direction of the Earth's supposed movement or opposite that movement, there was no effect on its speed going through the glass. Moreover, he showed that a light beam pointed toward or away from the Earth's supposed orbit had the same refraction in glass as the refraction of starlight in glass. Hence, in whatever way he tested the incidence of light, it always showed Earth at rest in the ether." - Sungenis*



The success of the experiment seems to me to render the adoption of Fresnel's hypothesis necessary, or at least the law which he found for the expression of the alteration of the velocity of light by the effect of motion of a body; for although that law being found true may be a very strong proof in favour of the hypothesis of

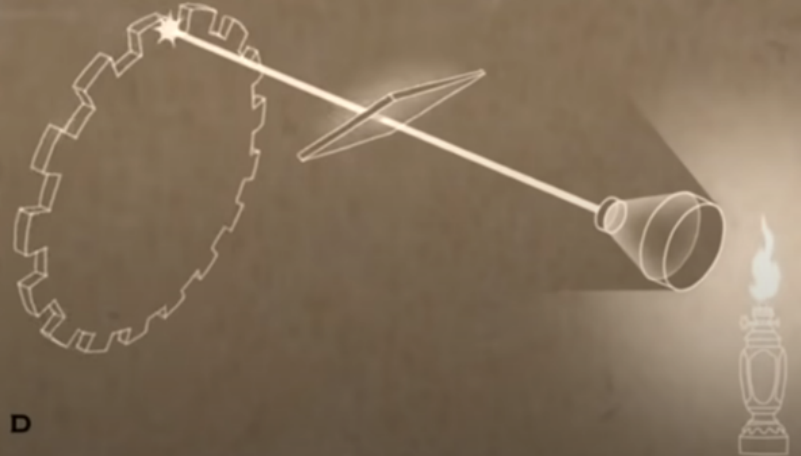

C R E D I T : T E D - E D

Note:

Hippolyte [Fizeau](#) (1849) / Using math and experiment, a proportional velocity relationship is measured using  $c$  and the rate of interference produced by the rotating cog. The fringe produced by the teeth in the cog was proportional to how fast the cog rotates.

Obs'd Phenom: Light propagating at some rate.

Problem/Question: What is the rate of induction of light? We know that the wavelength changes when a medium is introduced. Does the frequency change? Additionally, can we use a moving medium of some known refractive index so that we can deduce how much the rate of induction is effected by motion.

Hypo: Motion can be used to measure the frequency of.

Experiment: Using a toothed cog wheel at a fixed angular velocity and recording measurements over a specific duration, the light passing through the toothed cog produces intermittent flashes on a mirror. By analyzing the amount of flashes over the period of time, you can derive how fast  $c$  would have to be propagating to produce that amount of flashes over a given time.

Results:

Conclusion:

---

ON THE HYPOTHESES RELATING TO THE LUMINOUS ÆTHER, AND AN EXPERIMENT WHICH APPEARS TO DEMONSTRATE THAT THE MOTION OF BODIES ALTERS THE VELOCITY WITH WHICH LIGHT PROPAGATES ITSELF IN THEIR INTERIOR. BY M. H. FIZEAU.

MANY hypotheses have been proposed to account for the phenomena of aberration in accordance with the doctrine of undulations. Fresnel in the first instance, and more recently Doppler, Stokes, Challis, and many others, have published memoirs on this important subject; but it does not seem that any of the theories proposed have received the entire assent of physicists. In fact, the want of any definite ideas as to the properties of the luminous æther and its relations to ponderable matter, has rendered it necessary to form hypotheses, and among those which have been proposed there are some which are more or less probable, but none which can be considered as proved.

These hypotheses may be reduced to three principal ones. They refer to the state in which the æther existing in the interior of transparent bodies may be considered to be.

This æther is either adherent, and as it were attached to the molecules of bodies, and consequently participates in the motions to which the bodies may be subjected;

Or the æther is free and independent, and is not influenced by the motion of the bodies;

*Intelligence and Miscellaneous Articles.* 569

Or, lastly, according to a third hypothesis, which includes both the former ones, only a portion of the æther is free, the other portion being attached to the molecules of bodies and participating in their motion.

This latter hypothesis was proposed by Fresnel, and constructed for the purpose of equally satisfying the phenomena of aberration, and a celebrated experiment of M. Arago, by which it has been proved that the motion of the earth has no influence upon the refraction which the light of the stars suffers in a prism.

We may determine the value which in each of these hypotheses

Although the velocity of light is enormous comparatively to such as we are able to impart to bodies, we are at the present time in possession of means of observation of such extreme delicacy, that it seems to me to be possible to determine by a direct experiment what is the real influence of the motion of bodies upon the velocity of light.

We are indebted to M. Arago for a method based upon the phenomena of interference, which is capable of indicating the most minute variations in the indexes of refraction of bodies. The experiments of MM. Arago and Fresnel upon the difference between the refractions of dry and moist air, have proved the extraordinary sensibility of that means of observation.

It is by adopting the same principle, and joining the double tube of M. Arago to the conjugate telescopes which I employed for determining the absolute velocity of light, that I have been able to study directly in two mediums the effects of the motion of a body upon the light which traverses it.

I will now attempt to describe, without the aid of a diagram, what was the course of the light in the experiment. From the focus of a cylindrical lens the solar rays penetrated almost immediately into the first telescope by a lateral opening very near to its focus. A transparent mirror, the plane of which made an angle of 45° with the axis of the telescope, reflected the rays in the direction of the object-glass.

On leaving the object-glass, the rays having become parallel among themselves, encountered a double chink, each opening of which corresponded to the mouth of one of the tubes. A very narrow bundle

570 *Intelligence and Miscellaneous Articles.*

of rays thus penetrated into each tube, and traversed its entire length, 1<sup>m</sup>.487.

The two bundles, always parallel to each other, reached the object-glass of the second telescope, were then refracted, and by the effect of the refraction reunited at its focus. There they encountered the reflecting plane of a mirror perpendicular to the axis of the telescope, and underwent a reflexion back again towards the object-glass; but by the effect of this reflexion the rays had changed their route in such a way that that which was to the right before, was to the left after the reflexion, and *vice versa*. After having again passed the object-glass, and been thus rendered parallel to each other, they penetrated a second time into the tubes; but as they were inverted, those which had passed through one tube in going passed through the other on returning. After their second transit through the tubes, the two bundles again passed the double chinks, re-entered the first telescope, and lastly intersected at its focus in passing across the transparent mirror. There they formed the fringes of interference, which were observed by a glass carrying a graduated scale at its focus.

Note:

Ref. To M. Arago's telescope & prisms experiment that proves Earth's motion is null b/c it has NO effect on the refraction suffered by star light through a prism.

Orange Color: "it seems to me to be possible to determine by a direct experiment what is the real influence of the motion of bodies upon the velocity of light"

Green: Thanks Arago for helping us with the refractive indexes and interference patterns produced thereof so we can deduce the fringe produced by the velocity of the moving body (or media)

Measured absolute velocity of light by measuring the fringe displacement produced by refraction.

# Fresnel Drag

$$1 - \frac{1}{n^2}$$

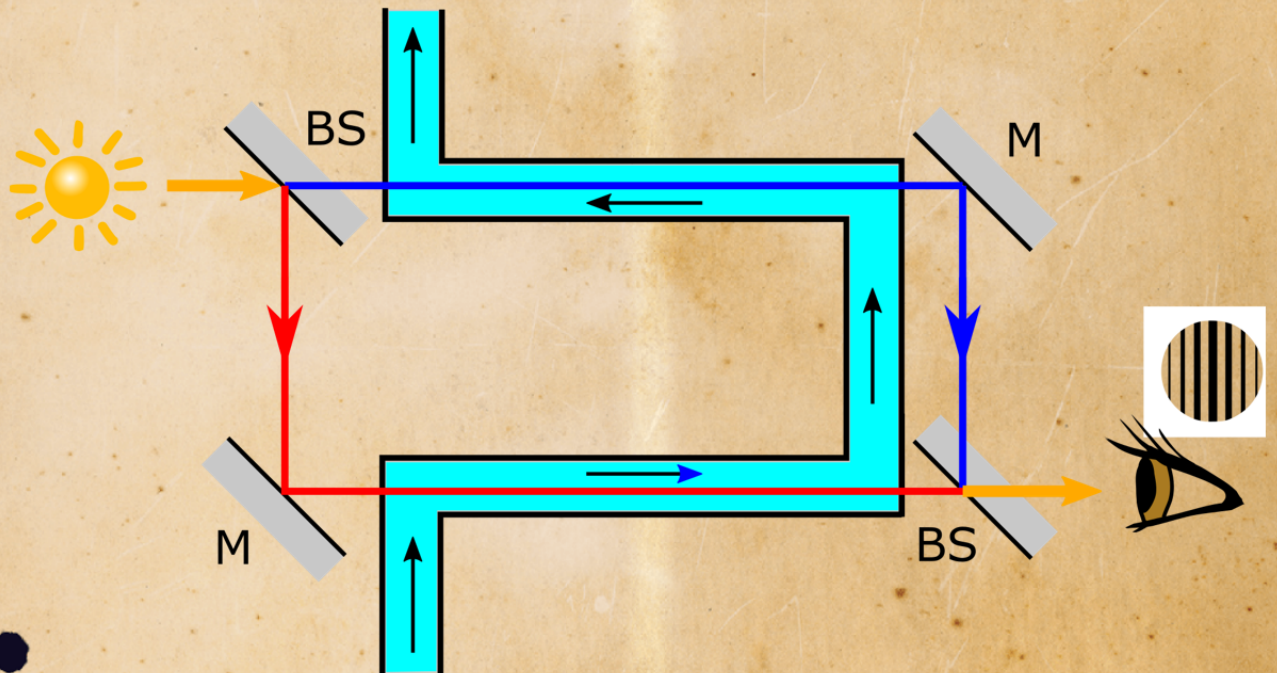

**44% Proportional Velocity!**

Note: we covered a lot on the wavelength side, let's cover the frequency, which is directly proportional to its induction rate.

Frequency measurements; Fizeau (1849) using running water, mirrors and prisms, he confirmed Fresnel's ether drag coefficient which uses the ratio of  $c$ , the refractive index of water AND the translation speed of the running water. Fizeau found there's a 44% proportional velocity relationship with the running water. Light gains a +44% boost to its propagation moving with the water and it loses -44% going against the water.

Frequency (Rate of Induction)

1. Light interacting with a solid object or media produces an diffraction and/or an interference pattern
2. The pattern produced is relative to the induction rate through that media.
3. A frequency change in light as it interacts with a media which causes the wavelengths to change

(proportionally)

## 4. By using motion, you can measure the frequency of light (rate of induction).

Recap: (Fizeau, water)

Obs'd Phenom.: Light behaving like a wave (diffracting and recombining, interference patterns)

Problem.: There's a change in wavelength when light propagates through a medium. Does its frequency change too? Could we use a moving medium to see if the translation speed affects the propagation of  $c$  through the medium.

Hypo. There will be translational speed gain observed in light as it propagates through a moving medium. The boost will likely be Galilean (meaning velocity addition) +/- refraction or there will be no change.

Experiment: Using focused light of a known wavelength, split a beam in a circuit such that it goes through moving water and against it to complete the circuit. When the circuit is complete, the beam is recombined and an interference pattern is observed.

IV: the velocity of the water, water (Refractive index)

DV:  $c$ , the fringe pattern recorded

Remember the freq. and induction rate are 1:1. The measurement of a fringe is the DV.

---

$$v = \frac{1}{\sqrt{\epsilon_0 \mu_0}} = c$$

Note:

SoL in a vacuum

$\mu_0$  = [magnetic permeability](#) | units measure: Henry's per meter (H/m) | 0.00000125663706212

$\epsilon_0$  = [electric permittivity](#) | units of measure: Farads per meter (F/m) | 0.000000000008854

J. C. Maxwell (1865) put this equation together by mathematizing Faraday's work.

Showcasing that rate of induction, the frequency of  $c$  will change with respect to the medium its propagating in.



Refraction indexes varying in magnetic permeability and dielectric permittivity. An adjustment to the refractive index will adjust the SoL proportionally to its propagation rate in a vacuum.

---

Cool story, but hasn't the aether been falsified?

Note: Only through mathematical reification and unsubstantiated terms in electromagnetic theory like Maxwell's [displacement current](#) term i.e. the mathematical reification that an electric current can self induce a magnetic field without accelerating charge potential can they begin the abstractly reify the momentum of a photon.

The frames that are alleged to be debunked are debunked because they're explicitly linked to attempts to measure Earth's orbital velocity as a first-order effect through first-order measurement.

---

Some title

Note: We have naturally observed phenomena of light behaving light like a wave. We have first-order effects and measurements of this behavior. So much so that we've measured its induction rate with the lowest amount of physical material that we can manufacture in a vacuum and yet there's a measured impendence which gives us an induction rate that we can use to make precise measurements with.

Knowing the failure of the historical ether theories regarding Earth's measurement. Let me purpose that absolute frame of rest that Newton discovered is actually the Earth. The sky is in absolute rotation. The material medium that's necessary for electromagnetic propagation to occur translates that motion down from the sky to the Earth,

It's that material background medium that will have a first-order effect on electromagnetic propagation. Through experiment, we'll go over the first-order measurements of these this effect and material background medium.

---

#### Atsukovsky Etherdynamics Model

1. Anisotropy Effect
  2. Height Effect
  3. Space Effect
  4. Hydroaerodynamic Effect
- 

#### Anisotropy Effect:

*The velocity of electromagnetic waves propagation depends on radiation direction, that is stipulated by the relative movement of the solar System and the ether - the medium, responsible for electromagnetic waves propagation.*

Note: Preferred direction; Independent of rotational effects i.e. no N/S variance. Only East -> West

---

*The velocity of wave propagation depends on the height above the Earth's surface, that is stipulated by the Earth's surface interaction with the viscous ether stream - material medium, responsible for electromagnetic waves propagation.*

Note: Height effect velocity of em propagation will be faster or slower depending on altitude. A vertical gradient of increased speed. (don't forget linear Galaev graph)

---

**The Space Effect:** the velocity of wave propagation changes its value with a period per one stellar day, that is stipulated by a space (galactic) origin of the ether drift | the medium, responsible for electromagnetic waves propagation. Thus the height (astronomical coordinate) of the Solar system movement apex will change its value with the period per one stellar day as well as for any star owing to the Earth's daily rotating. Therefore the velocity horizontal component of the ether drift and, hence, the velocity of electromagnetic wave propagation along the Earth's surface will change the values with the same period.

Note: There will be a periodicity through the day were the velocity of em propagation will reach its minimum and maximum speeds. The minimum and maximum dimensions should be reached on the equinoxes, as that's when there's supposed to be a change in Earth's orbital velocity around the sun.

---

*The hydroaerodynamic effect* — the velocity of electromagnetic waves propagation depends on movement parameters of viscous gas-like ether in directing systems (for example, in tubes), that is stipulated by solids interaction with the ether stream — material medium, responsible for electromagnetic waves propagation. (As it is known, the law of fluids and gases motions and their interaction with solids is learnt by hydroaerodynamics. This effect, apparently, should be called as the *ether-dynamics* effect with reference to the ether dynamics. It can be seen, that "the height effect" is referred to the etherdynamic effect class. However in the work, by virtue of methodical reception distinction used for their discovery, the effects are indicated as separate).

Note: The equations that describe the laws of gases and fluids should be able to describe the kinematic viscosity of the ether based on how electromagnetic propagation is effected by Fermi surfaces and dielectric insulators. A Fermi surface any conductor electricity, typically metal.

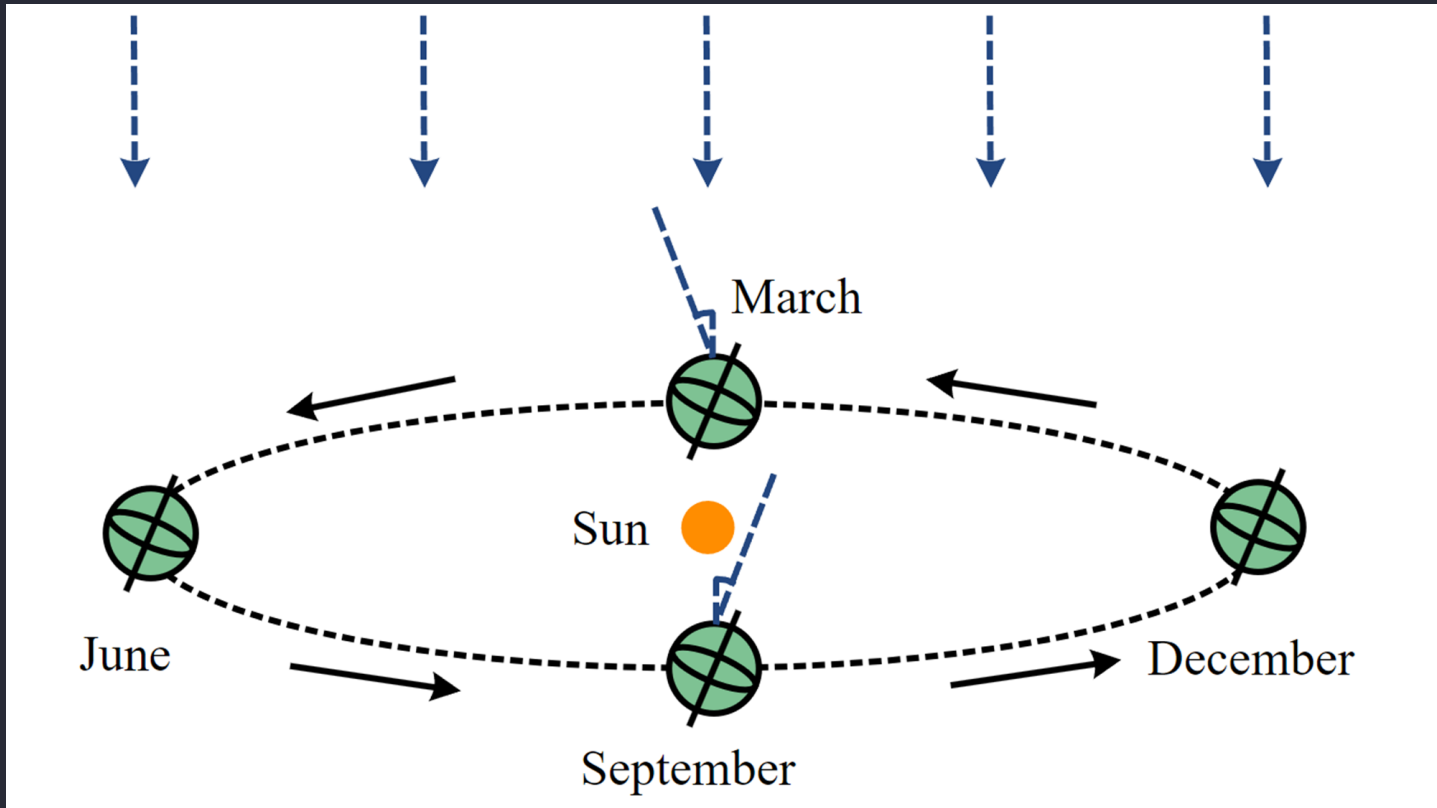

## Note: James Bradley (1728) measures stellar aberration

$$v/c = \theta \quad (v = 30\text{km/s}, \theta = 20'', c = \text{SoL})$$

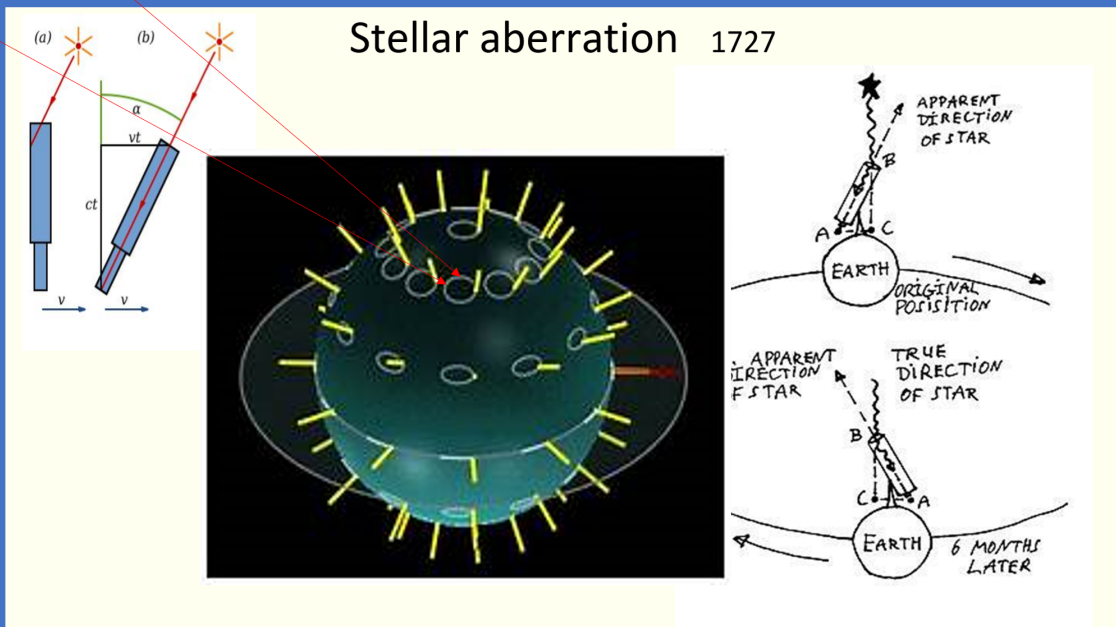

Note:

This an observation.

Not an experiment.

This observations

Yields Measurements.

First-order ratio in  $v/c$ . This is to say the angle was caused by the velocity component and is entirely responsible for it since it's proportional to the angle theta (20 arcseconds).

It cannot tell you if the Earth is in motion or if there's an ether carrying the starlight at 30km/s

Measurements = Kinematics

---

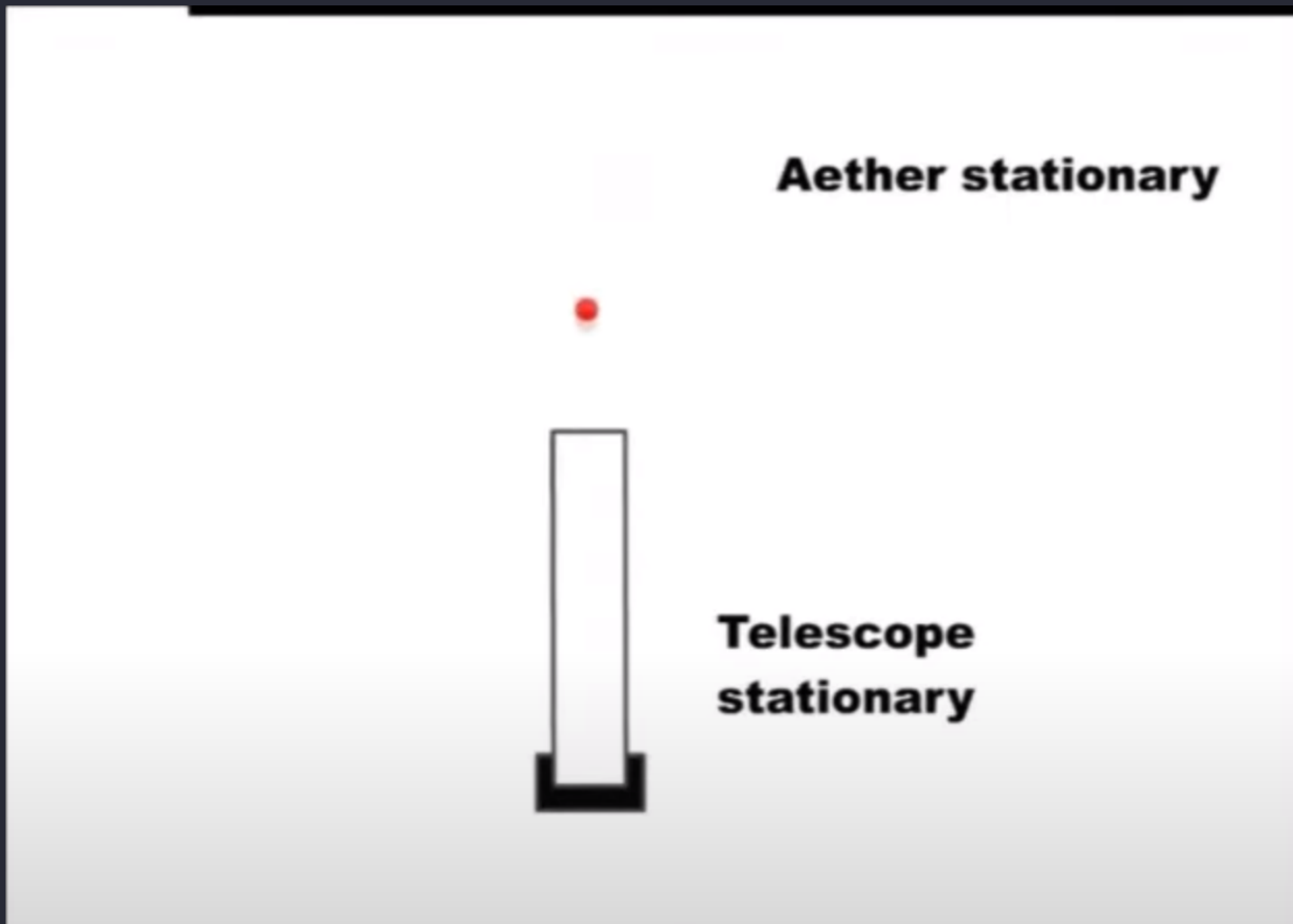

Note: Shoutout to [Malcom Bowden](#). Airy's success: Stationary Earth, stationary ether, no correction needed. Starlight will travel directly to the back of the telescope.

---

# Aether stationary

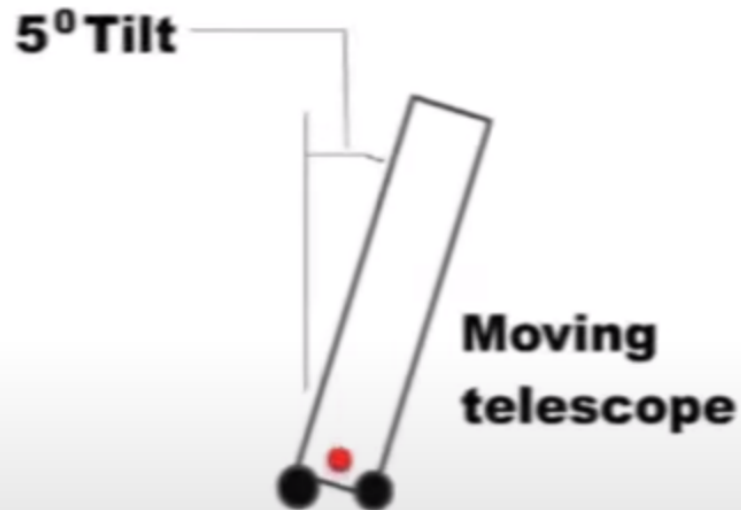

Note: In 1729 James Bradley, with his telescope angled at  $90^\circ$ , found that to get a star in the center of the telescope, he had to tilt it slightly. This was taken as confirm of Earth's motion around the sun.

Here we'll apply the kinematic and dynamic analysis: Suppose the Earth is moving at 5mi/h, you would need to correct your telescope by  $5^\circ$  to compensate. On the other hand you're at rest and the starlight is being carried by ether that's in rotation with the sky at 5mi/h.

You'd have to make the same correction so the correction angle doesn't tell us which is moving.

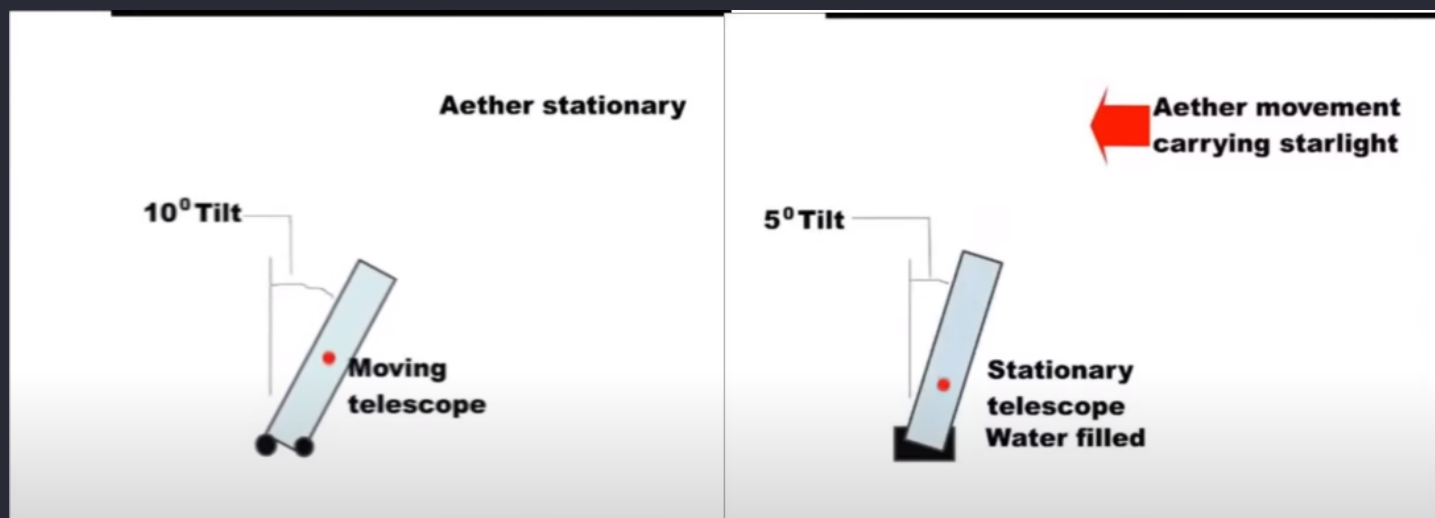

Note: By manipulating the independent variable of the medium through which the starlight is propagating in, the answer can be deduced.

# 1. Record the normal tipping angle for any particular star

# 2. Fill the telescope with water.

The starlight propagating through the telescope will be significantly reduced by the water so you will have to further compensate for your velocity by tipping the telescope forward.

If no correction angle is needed, then the implication is that the starlight is already coming with a 5° drift relative to your fixed position.

Recap: If Earth is in motion, you need to tilt the telescope to make an additional correction for when its filled with water. If the telescope is stationary and the starlight is drifting past us, then it doesn't need tipped further.

## 38 On a supposed Alteration of Aberration of Light &c. [Nov. 23,

Day of observation.	Star's Observed Zenith-distance North.	Star's Declination from 'Nautical Almanac.'	Difference for Geographical Latitude of Instrument.	Correction for Aberration adopted in 'Nautical Almanac.'
1871.				
Feb. 28 .....	85°30	51° 29' 59.3	51° 28' 34.0	-18.71
March 1 .....	85°71	59.1	33.4	18.82
3 .....	84°19	58.9	34.7	19.02
4 .....	82°18	58.8	36.6	19.11
16 .....	83°63	58.0	34.4	19.73
17 .....	84°58	58.0	33.4	19.74
21 .....	83°87	57.9	34.0	19.73
23 .....	82°73	57.9	35.2	19.69
24 .....	84°18	58.0	33.8	19.66
26 .....	84°04	58.1	34.1	19.59
27 .....	83°48	51 29 58.2	51 28 34.7	-19.54
Mean Latitude of Instrument from Spring Observations .....			51 28 34.4	
Aug. 29 .....	122°10	51 30 34.4	51 28 32.3	+18.25
Sept. 5 .....	121°84	35.0	33.2	19.01
7 .....	121°62	35.1	33.5	19.18
9 .....	120°27	35.2	34.9	19.33
11 .....	122°98	35.3	32.3	19.45
15 .....	122°20	35.4	33.2	19.64
17 .....	121°53	35.5	34.0	19.70
22 .....	121°38	35.5	34.1	19.74
24 .....	120°01	35.4	35.4	19.72
Oct. 1 .....	120°62	35.1	34.5	19.46
2 .....	120°29	35.1	34.8	19.40
3 .....	121°31	35.0	33.7	19.33
4 .....	124°41	34.9	30.5	19.26
6 .....	120°60	51 30 34.8	51 28 34.2	+19.10
Mean Latitude of Instrument from Autumn Observations .....			51 28 33.6	

51° 28' 34.4"

Only 0.8" difference

51° 28' 33.6"

Note:  
0.8" deviation. Predicted amount: 30".

0.8 arcseconds is a FRACTION of an arcsecond which is already 1/3600th of a degree.

Remarking that the mean results for Geographical Latitude of the Instrument (determined from observations made when the Aberration of the star had respectively its largest + value and its largest - value) agree within a fraction of a second, I think myself justified in concluding that the hypothesis of Professor Klinkerfues is untenable. Had it been retained, the Aberrations to be employed in the corrections would have been increased by +15" and -15" respectively, and the two mean results would have disagreed by 30".

Note: Wikipedia will tell you that this experiment it somehow failed to prove the ether.

The fact that no correction angle was required for the telescope in water tells us that the starlight drifting, not us.

---

AI IMAGE

Note:

Airys' Failure, First-order experiment: The measurement is taken on a one-way path.

The effect of ether wind displacement of starlight was measured to the first-order with the correction angle given of 0.8 arcseconds.

Airy's Success / They already knew light's propagates slower in media. This was experimentally shown and the accompanying math to describe the proportional relationship with a fringe and velocity was already understood.

Calling back to Fresnel, Fizeau and Arago, they already measured it and the relationship has been shown.

By introducing an IV/DV to the observation. The truth of the matter was obtained. The starlight is already coming in with a drift. That's why it requires a slight correction without being filled with water and why it requires a slight correction in water. Fractions of an arcsecond. As opposed to accounting for the assumed velocity component of Earth where the correction angle was expected to be 30 arcseconds.

---

# ALL YOUR LASER INTERFEROMETRY NOW BELONGS TO US

Allow this to serve as a guide through the history of experimental evidence that proves the Earth does not move and the existence of the ether

Note: Okay now that we've gone over the scientific method, philosophy, the history of wavelengths, frequencies, refraction, and how light is used to measure motion via fringe displace; let's analyze what exactly happened with Michelson-Morley and the continued history of interferometry.

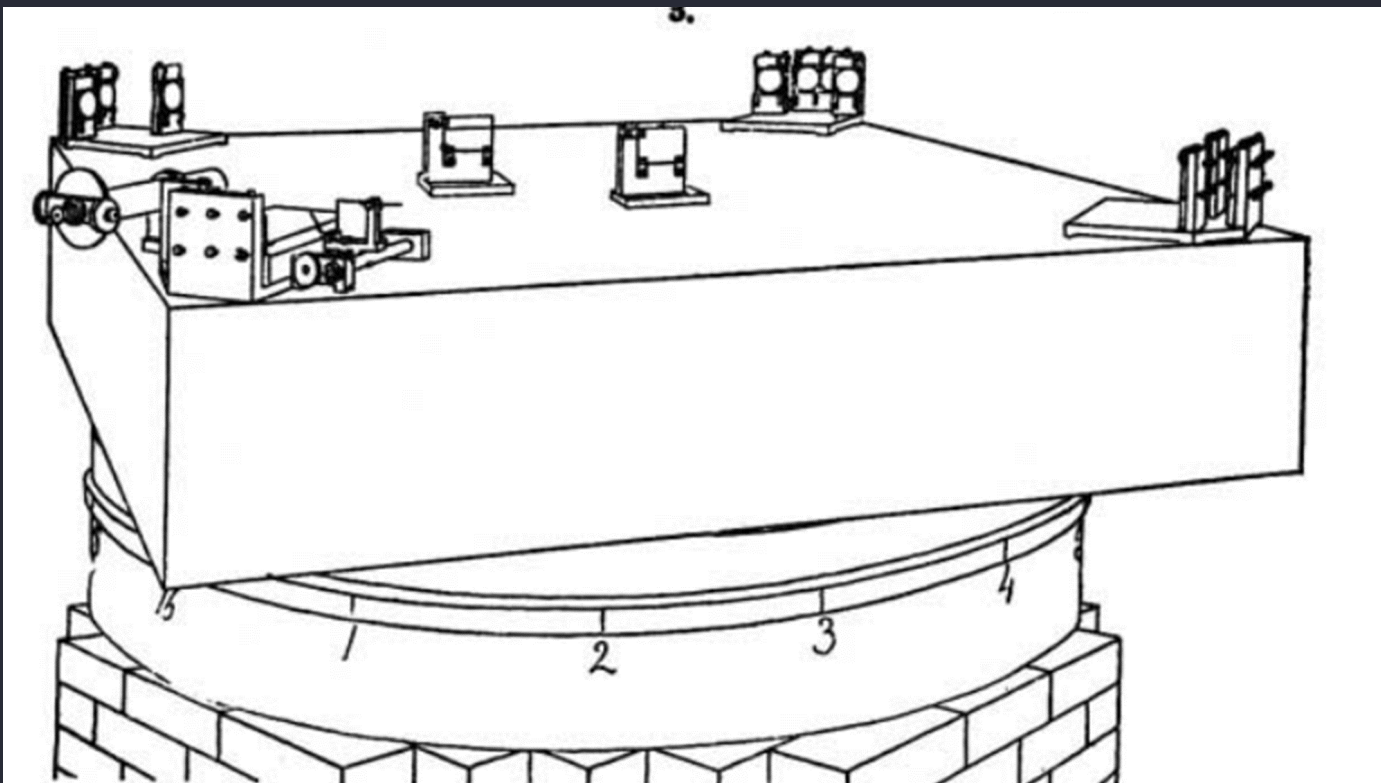

Michelson-Morley 1887



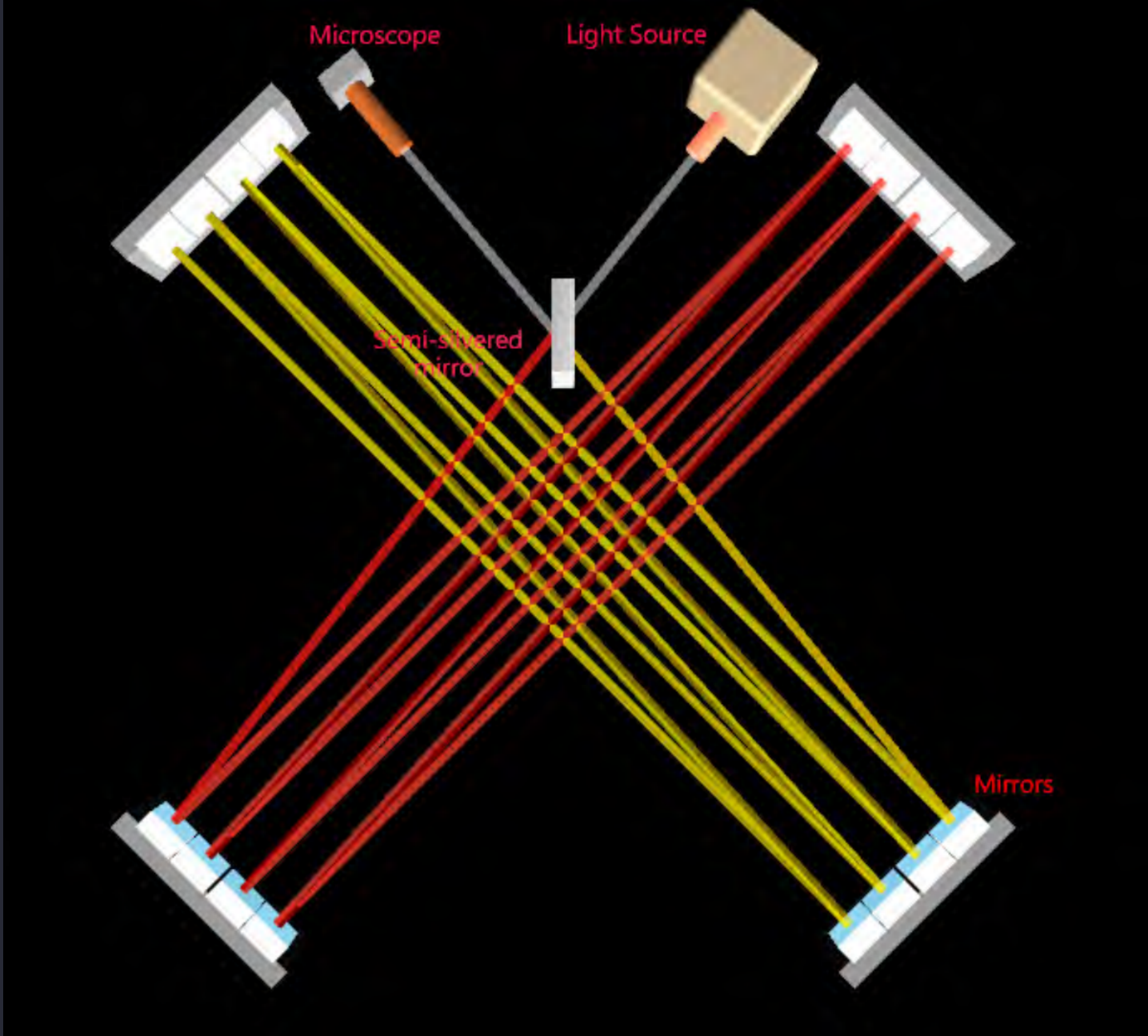

Note: Topographical view of the Michelson interferometer.

Notice the travel path of light in this confirmation. This setup is a second-order experiment because it's based on a return-trip of light.

---

Let  $V$  = velocity of light.

$v$  = velocity of the earth in its orbit.

$D$  = distance  $ab$  or  $ac$ , fig. 1.

$T$  = time light occupies to pass from  $a$  to  $c$ .

$T_1$  = time light occupies to return from  $c$  to  $a$ , (fig. 2.)

Then  $T = \frac{D}{V-v}$ ,  $T_1 = \frac{D}{V+v}$ . The whole time of going and coming is  $T + T_1 = 2D \frac{V}{V^2 - v^2}$ , and the distance traveled in this time

is  $2D \frac{V^2}{V^2 - v^2} = 2D \left(1 + \frac{v^2}{V^2}\right)$ , neglecting terms of the fourth order.

The length of the other path is evidently  $2D \sqrt{1 + \frac{v^2}{V^2}}$ , or to the

same degree of accuracy,  $2D \left(1 + \frac{v^2}{2V^2}\right)$ . The difference is there-

fore  $D \frac{v^2}{V^2}$ . If now the whole apparatus be turned through  $90^\circ$ ,

the difference will be in the opposite direction, hence the displacement of the interference fringes should be  $2D \frac{v^2}{V^2}$ . Con-

$$2Dv^2/V^2$$

Note: Mathematics, this a second-order approximation. The aim here by using a second-order measurement i.e. multiple there-and-back trips for the path of light and use that as an average. By doing this, the hope is to get a more statistically reliable measurement that can be analyzed very precisely.

tions and distances traversed by the rays will be altered thus:—  
The ray  $sa$  is reflected along  $ab$ , fig. 2; the angle  $bab$ , being equal to the aberration  $=\alpha$ , is returned along  $ba_1$ , ( $aba_1 = 2\alpha$ ), and goes to the focus of the telescope, whose direction is unaltered. The transmitted ray goes along  $ac$ , is returned along  $ca_1$ , and is reflected at  $a_1$ , making  $ca_1e$  equal  $90 - \alpha$ , and therefore still coinciding with the first ray. It may be remarked that the rays  $ba_1$  and  $ca_1$  do not now meet exactly in the same point  $a_1$ , though the difference is of the second order; this does not affect the validity of the reasoning. Let it now be required to find the difference in the two paths  $aba_1$  and  $aca_1$ .

fore  $D \frac{v^2}{V^2}$ . If now the whole apparatus be turned through  $90^\circ$ , the difference will be in the opposite direction, hence the displacement of the interference fringes should be  $2D \frac{v^2}{V^2}$ . Con-

IV/DV

Note:

Hypo.: If the Earth is in motion, when the interferometer is aligned in the direction of motion, the orthogonal arm will be dragged against the aether and a variance in  $c$  proportional that velocity will be measured when the wavelengths recombine.

IV: White light, Orientation, measurements at different times of day

DV: The measured fringe pattern

The results of the observations are expressed graphically in fig. 6. The upper is the curve for the observations at noon, and the lower that for the evening observations. The dotted curves represent *one-eighth* of the theoretical displacements. It seems fair to conclude from the figure that if there is any dis-

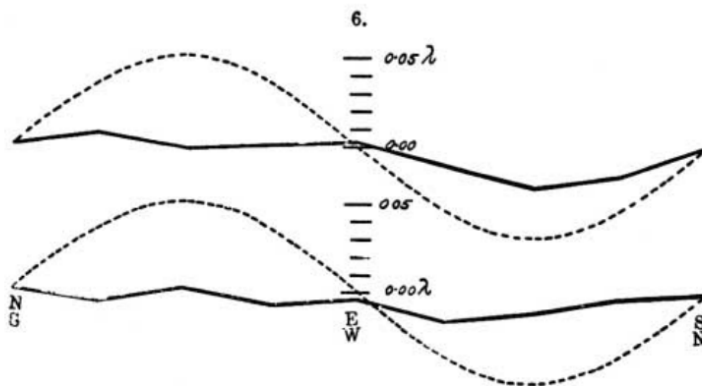

placement due to the relative motion of the earth and the luminiferous ether, this cannot be much greater than 0.01 of the distance between the fringes.

Considering the motion of the earth in its orbit only, this displacement should be  $2D \frac{v^2}{V^2} = 2D \times 10^{-8}$ . The distance  $D$  was

about eleven meters, or  $2 \times 10^7$  wave-lengths of yellow light; hence the displacement to be expected was 0.4 fringe. The actual displacement was certainly less than the twentieth part of this, and probably less than the fortieth part. But since the displacement is proportional to the square of the velocity, the relative velocity of the earth and the ether is probably less than one sixth the earth's orbital velocity, and certainly less than one-fourth.

In what precedes, only the orbital motion of the earth is considered. If this is combined with the motion of the solar system, concerning which but little is known with certainty, the result would have to be modified; and it is just possible that the resultant velocity at the time of the observations was small, though the chances are much against it. The experiment will therefore be repeated at intervals of three months, and thus all uncertainty will be avoided.

It appears, from all that precedes, reasonably certain that if there be any relative motion between the earth and the luminiferous ether, it must be small; quite small enough entirely to refute Fresnel's explanation of aberration. Stokes has given a theory of aberration which assumes the ether at the earth's surface to be at rest with regard to the latter, and only requires in addition that the relative velocity have a potential; but Lorentz shows that these conditions are incompatible. Lorentz then proposes a modification which combines some ideas of Stokes and Fresnel, and assumes the existence of a potential, together with Fresnel's coefficient. If now it were legitimate to conclude from the present work that the ether is at rest with regard to the earth's surface, according to Lorentz there could not be a velocity potential, and his own theory also fails.

Note:

Dotted line is the theoretical expected curved.

The conclusion in the paper: If there is relative motion of the Earth and ether, it must be small. The fringe displacement is proportional to a velocity measured of 6 to 7 km/s (13,400 mi/h)

---



Note: The reason all of physics was redefined over this experiment is because of that proportional velocity relationship. As we continue, the same equations will be used to measure a first-order effect in angular velocity. Michelson Morley was an attempt to measure a linear velocity.

Although the Earth is in orbit around the sun, the orbital circumference is so big, the curved portion of the orbit might as well be considered linear.

From this point on, orthogonal or right-angle interferometers were said to be unable to measure linear motion. The variance in  $c$  that produced the fringe was rounded to zero. Meaning the SoL is constant.

Using that assumed constancy, light was turned into a ridged measuring stick by which all of physics and the universe would measure with its invariance.

Using a Lorentz transformation, an entirely new framework of mathematics that exist only as the second-order effects of length contraction and time dilation is put forward to explain a first-order velocity effect that was measured in the second-order.

Through the relativistic transformation, the first-order velocity effect of 6 km/s is reified through the second-order effect of length contraction in the apparatus that contracted proportional to the assumed 30 km/s velocity.

This unfalsifiable premise of contraction in the frame before the measurement even takes place can now be gamma-factor ratio'd to explain the missing 24 km/s and give the appearance of an explanation. Once accepted, this framework retroactively explain almost anything.

Especially if people don't realize the significance and history of these measurements

---

Examples of this sort, together with the unsuccessful attempts to discover any motion of the earth relatively to the "light medium," suggest that the phenomena of electrodynamics as well as of mechanics possess no properties corresponding to the idea of absolute rest. They suggest rather that, as has already been shown to the first order of small quantities, the same laws of electrodynamics and optics will be valid for all frames of reference for which the equations of mechanics hold good.<sup>1</sup> We will raise this conjecture (the purport of which will hereafter be called the "Principle of Relativity") to the status of a postulate, and also introduce another postulate, which is only apparently irreconcilable with the former, namely, that light is always propagated in empty space with a definite velocity  $c$  which is independent of the state of motion of the emitting body. These two postulates suffice for the attainment of a simple and consistent theory of the electrodynamics of moving bodies based on Maxwell's theory for stationary bodies. The introduction of a "luminiferous ether" will prove to be superfluous inasmuch as the view here to be developed will not require an "absolutely stationary space" provided with special properties, nor

---

<sup>1</sup>The preceding memoir by Lorentz was not at this time known to the author.

assign a velocity-vector to a point of the empty space in which electromagnetic processes take place.

Note: Before we continue, let's read the rule book for the competing non-aetheric framework. As we continue reading on, we'll compare the relativistic interpretation along with the classical.

important thing to note is that Einstein makes two specific claim regarding the "[luminiferous ether](#)"

1. The newly purposed theory will not require an "absolutely stationary space" provided with special properties.
2. No assignment of a velocity-vector to a point of empty space in which electromagnetic process

# takes place.

---

It is at once apparent that this result still holds good if the clock moves from A to B in any polygonal line, and also when the points A and B coincide.

If we assume that the result proved for a polygonal line is also valid for a continuously curved line, we arrive at this result: If one of two synchronous clocks at A is moved in a closed curve with constant velocity until it returns to A, the journey lasting  $t$  seconds, then by the clock which has remained at rest the travelled clock on its arrival at A will be  $\frac{1}{2}tv^2/c^2$  second slow. Thence we conclude that a balance-clock<sup>7</sup> at the equator must go more slowly, by a very small amount, than a precisely similar clock situated at one of the poles under otherwise identical conditions.

Note: Where do Einstein's equation's apply? in inertial ref frames. Is a uniformly rotating platform an inertial frame? According to Einstein and the logic he used to put his theory forward: YES

It actually has to be. It logically tracks that a closed polygonal loop extended to infinity will be dang near linear.

---

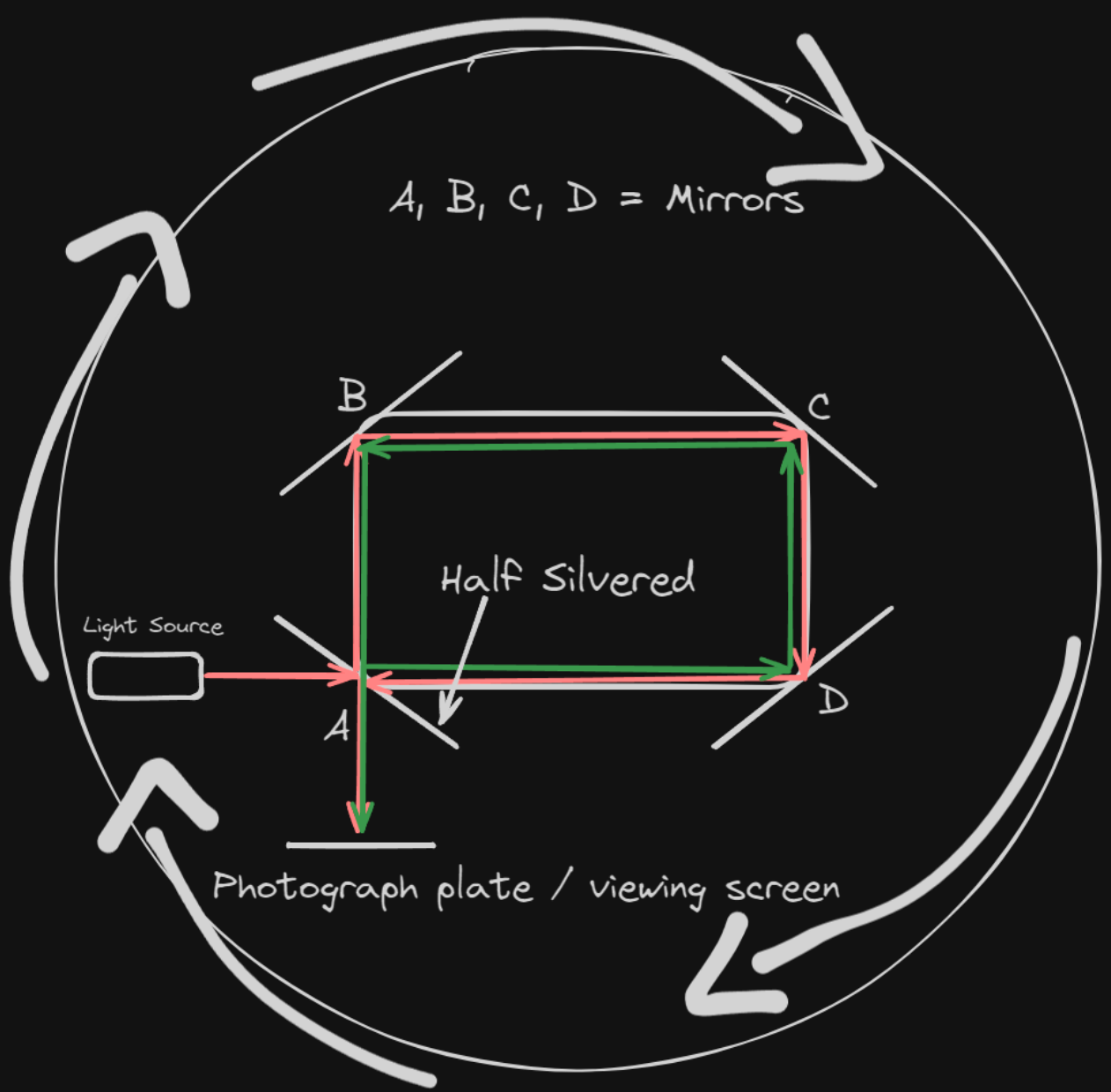

Note: Sagnac IV/DV

Continuing the experiments using light and motion, [Sagnac](#) in 1913 using a uniformly rotating platform came along and showed that  $c$  is not constant in an inertial frame. True to the specifications of Relativity theory by Einstein's own words about a uniformly rotating closed polygonal circuit.

It was easier for me to first find a proof for the ether's existence by rotating a small optical circuit. A rotational frequency  $N$  of two turns per second gave me a rotational density of  $4\pi N$  relative to the ether for a rotation of 25 rad. per second. A uniform *left-hand rotation* of the interferometer produces a *left-handed ether wind*; and delays by  $x$  the phase of the beam ( $T$ ) whose motion around the area  $S$  is *right-handed*, and advances by the other beam  $R$  by the same amount, thus displacing the fringes by  $2x$  units. The displacement  $z$  that I observe between images  $s$  and  $d$  should be twice that of the former\*. On the basis of the value of  $x$  observed earlier (*loc. cit.*, 1910 and 1911), we have

$$z = 4x = 4 \frac{bS}{\lambda V_0} = \frac{16\pi NS}{\lambda V_0};$$

where  $V_0$  is the speed of light in vacuum, and  $\lambda$  is the operating wavelength.

For a rotational frequency of  $N = 2$  per sec., and the path area  $S$  being  $860 \text{ cm}^2$ , the observed value of  $z$  is 0.07 when using indigo light, and is easily visible in the photographs I attach to this Note and where the fringe-spacing is between 0.5 and 1.0 mm.

Note:

First-order effect uniform angular rotation (velocity)

IV: Rotor's angular velocity

DV: Fringe produced by the movement when compared to when the interferometer is stationary.

Math: First-order derivation in  $v/c$

---



**§2. Optical rotation effect.** — Measured from the fring-spacing, the displacement  $z$  from the interference centre that I observed with the preceding method is a particular case of the optical rotation effect that I have defined earlier (*Congrès de Bruxelles de septembre*, 1910, tome 1, page 217; *Comptes rendus*, tome 152, 1911, page 310; *Le Radium*, tome VIII, 1911, page 1), and which, in the context of current ideas, should be construed as a direct observation of the luminiferous ether.

In a system moving as a whole relative to the ether, the propagation time between any two points of the system should change in a way similar to a stationary system subjected to an ether wind, the relative speed of which at each point of the system will be the same and directly opposite to the speed of any point, and would contain light waves in a manner similar to atmospheric wind carrying sound waves. The observation of the optical effect of such an *ether wind relative to the [stationary] ether* will constitute a proof of the ether's existence, just as the observation of a wind relative to the atmosphere on the speed of sound in a moving system would constitute — everything else being equal — a proof of the existence of a stationary atmosphere enveloping the moving system.

---

The interference displacement  $z$ , a constant fringe-spacing for the same value of rotation frequency  $N$ , disappears on the photographs when the fringes were made sufficiently narrow; this shows that the observed effect is very much due to a *phase difference* related to the rotational motion of the system and that (thanks to counter-screws that prevent movement of the mounting screws of the optical components) the displacement of the interferogram, observed in the comparison of image  $s$  with image  $d$ , does not arise from accidental relative displacements or elastic effects in the optical components during rotation.

Turbulent air produced above the interferometer by a fan rotating about a vertical axis and blowing downwards does not produce any displacement of the interferogram's centre, given a careful superposition of the two opposite beams. Any turbulent air, analogous and less intense, produced during rotation of the system does not affect the experiment.

The observed interference effect is very much the effect of optical rotation due to the motion of the system relative to the ether, and directly shows the existence of the ether, a necessary condition for the luminiferous waves proposed by Huygens and Fresnel.

It is at once apparent that this result still holds good if the clock moves from A to B in any polygonal line, and also when the points A and B coincide.

If we assume that the result proved for a polygonal line is also valid for a continuously curved line, we arrive at this result: If one of two synchronous clocks at A is moved in a closed curve with constant velocity until it returns to A, the journey lasting  $t$  seconds, then by the clock which has remained at rest the travelled clock on its arrival at A will be  $\frac{1}{2}tv^2/c^2$  second slow. Thence we conclude that a balance-clock<sup>7</sup> at the equator must go more slowly, by a very small amount, than a precisely similar clock situated at one of the poles under otherwise identical conditions.

Note: Special Relativity, as stated by Einstein says a clock will be slowed by  $1/2$  its fixed speed, times the (t)ime of the event, times the velocity of clock A velocity squared / c squared.

Can this equation explain the desynchronization between a stationary clock and a moving clock in the same way the Michelson-Morley experiment derived a proportional velocity using  $2Dv^2/c^2$

It will later be shown that Einstein's method for clock synchronization based of the constancy of  $c$  is incorrect. We'll come back to that later, though. For let's focus on the important part: Einstein defines an inertial frame as any closed polygonal loop in uniform rotation. In this frame, according to the postulates of Special Relativity, the speed of light must always =  $c$  in this frame.

If  $c$  were constant, no fringe shift could be derive. The equation given two us by Einstein can only explain a Doppler shift in the frequency of light proportional to the velocity, but it could  $c$  being out phase being out sync proportional to that velocity as well.

In SR there is no mechanism of contraction or dilation that can explain the physical fringe in a local uniformly platform with a light source and mirrors attached to it.

Relativists must ignore Einstein's explicit definition of what constitutes as an inertial frame, which was the entire premise of his Special Theory extending a closed polygonal circuit to claim it's linear motion and can't be measured.

Sagnac went answered until 1917 via transformations that could not explain the physical fringe displacement.

It wasn't until 1918 when Paul Langevin treated the uniformly rotating inertial frame as an accelerating frame, i.e. non-inertial, Langevin was able use a special metric tensor to satisfy the conservations laws on the small scale so he could conserve the energy of the rotation as a gravitational field that generates temporal pockets that dilate and contract the rotating apparatus.

---

A number of comprehensive articles [14, 25–28] have described various aspects of the Sagnac effect and have also undertaken to elucidate the conceptual difficulties that seem to be encountered in its interpretation. Various authors have derived the Sagnac phase shift in a number of ways: by optical analogy [13], general relativity considerations [10, 29, 30], special relativity analyses [28, 31–35], the WKB approximation [15], the Doppler effect of moving media in an inertial frame [36], a classical kinematical derivation [22, 37–39], dynamical analysis in a noninertial frame [40, 41], by analogy with the Aharonov-Bohm effect [42], by extension of the hypothesis of locality [43], by adiabatic invariance [44], using ether concepts [45], and in other ways. This great variety (if not disparity) in the derivation of the Sagnac phase shift constitutes one of the several controversies (recounted, e.g., in [31, 46, 47]) that have been surrounding the Sagnac effect since the earliest days of studying interferences in rotating frames of reference.

The classical kinematical derivation, as it has been used by many authors (see above), has the advantage of yielding the correct first-order result in a very simple and intuitive way. Its starting point is a considera-

Note: Nicklaus lists 24 papers that give a Special Relativity derivation for the Sagnac effect. Yet none can explain the actual fringe pattern. Save for Langevin's explanation. At least that derivation can explain the fringe by contraction. Further of note: SR and GR cannot explain the fringe mathematically unless from the center of the rotating platform. A "geometrically convenient" must be taken to even bein the second-order framework of Relativity's roleplay.

---

## Sagnac Effect Versus Special Relativity

The Sagnac effect, and the effect calculated by the Theory of Special Relativity (SR) are of different orders of magnitude. SR stipulates that the time of the traveler ( $t'$ ), is slower than that of the stationary observer ( $t_0$ ).

$$t_0 = t' \gamma \quad (2)$$

where  $t_0$  is the time for the light to travel a certain distance, as measured in the stationary laboratory,  $t'$  is the time for the light to complete the same distance as

measured aboard the object, traveling at uniform relative speed and  $\gamma = (1 - v^2/c^2)^{-0.5}$ . Using Binomial expansion:

$$t_0 - t' = t' (v^2/2c^2) \text{ and}$$

$$\frac{t_0 - t'}{t_0} = \frac{v^2}{v^2 + 2c^2} \quad (3)$$

$$= dt_R \text{ the Relativity time ratio.}$$

In the Sagnac case  $t_0$  is the time for a light signal to traverse a stationary circular disc, and  $t'$  is the time to traverse the spinning disc against the direction of spin, according to the observer on the disc.

$$t_0 = (2\pi r/c) \text{ and } t' = 2\pi r/(c+v)$$

$$\frac{t_0 - t'}{t_0} = \frac{v}{c + v} \quad (4)$$

$$= dt_S \text{ the Sagnac ratio.}$$

=  $dt_S$  the Sagnac ratio.

The ratio of  $dt_S$  to  $dt_R$  is :-

$$\frac{v^2 + 2c^2}{v [c + v]} \quad (5)$$

which for small values of  $v$  is  $2c/v$ .

The Sagnac effect is far larger than the effect forecast by SR. In the Pogany (1926) Sagnac test, where  $v$  was about 20 m/s, this ratio is 30,000,000. Post agrees that the dilation factor of SR is  $v/c$  smaller than the Sagnac effect.

Einstein did not address the contradiction to his theory in the M&G test even though he visited the team working on this problem in 1921. According to Turner (1979), Einstein never referred to the Sagnac test.

Note: It's shown here that Pogany (1926) showing the SR derivation is unable to explain the first-order effect of rotational velocity. Even though it was explicitly stated by Einstein that his equations would hold true in that frame.

Notice here that the ratio is between a hypothetical stationary observer at the center of the rotating platform and the timer difference between him and photographic recorder, who is also on the rotating platform, but does not have the benefit of being considered stationary.

From the stationary position, the distance traveled for the rotating platform is preserved as to explain the frequency shift in  $c$ . The frequency shift is the speed changing to produce the fringe. But remember, in Relativity  $c = c$  in inertial frames.

Again, here to even attempt to explain this framework; ABSOLUTE SPACE and TIME must be invoked to preserve a distant traveled and imaginary vectors must be used to describe and area where electromagnetic propagation once occurred.

Without violating its own postulates and prefaces, Special Relativity has completely failed on the face of it.

Mechanistically, the only thing the ether model has failed is failed to support the heliocentric model with a first-order measurement of the alleged first-order effect of a 30 km/s velocity. Through a stationary Earth WRT a rotating sky, the aether framework remains unchallenged as a viable framework of interpretation.

---

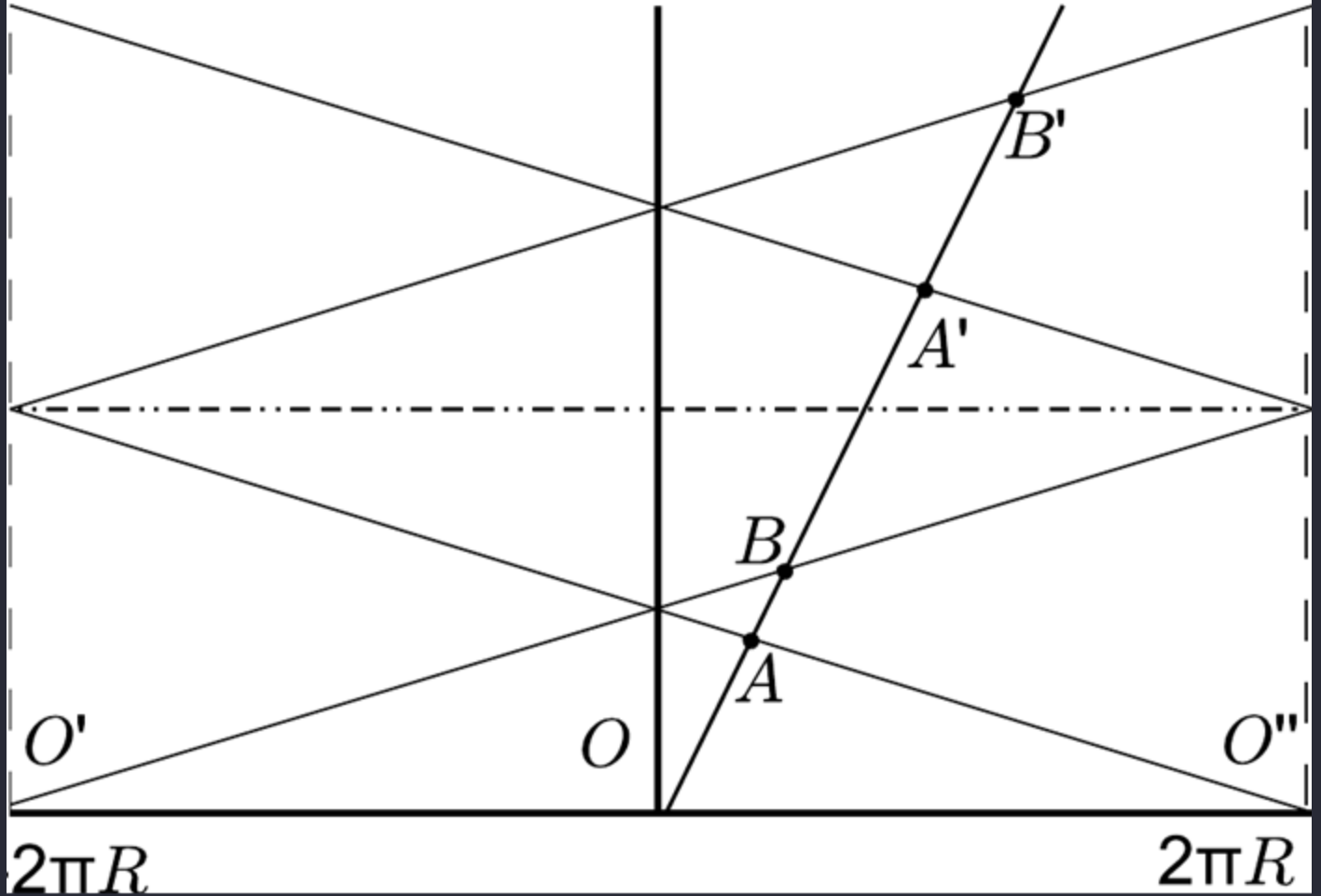

FIG. 2: Same as Fig. I. The cylinder has been cut along a generatrix passing through the rotating observer at time 0, and opened. For convenience, in order to make the picture more compact, two replicas of the opened cylinder are shown side by side: one enrolled to the right, the other to the left. Points  $O'$  and  $O''$  coincide with  $O$ . Four windings are shown. The vertical straight line is the world line of an inertial observer at rest with the axis of the disk.  $AB$  is the Sagnac effect expressed in terms of proper time of the rotating observer.

Note: To this day, Tartaglia, and Bhadra can't explain the Sagnac effect's physical fringe. They can't explain the second-order Doppler shift proportional to the velocity of the rotating platform without invoking absolute space.

1. Tartaglia, A. and M. L. Ruggiero (2015). "The Sagnac Effect and Pure Geometry." *American Journal of Physics* 83(5): 427-432.
2. Bhadra, A., et al. (2022). "A Quest for the Origin of the Sagnac Effect." *European Physical Journal C* 82: 649.

# CLASSIC EXPLANATION FOR SAGNAC [TARTIG]

*“The Sagnac effect may easily be described in classical terms if one assumes that the speed of light is  $c$  with respect to a static ether. Considering the rotating platform mentioned in the Introduction you see that it will take longer for light to reach again the emission point on the rim of the platform just because, meanwhile, the receiver will have moved forward by a distance  $\Delta l_+ = vt_+$  where  $t_+$  is the total time of flight and  $v$  is the velocity of the emitter with respect to the ether; the geometric length of the path is  $l$ .”*

$$\Delta t = t_+ - t_- = \frac{2lv}{c^2 - v^2}$$

Note: Even under second-order approximation, the first-order effect is fully accounted for.

$t_+$  = going with ether wind

$t_-$  = going with the ether wind

$2lv/c^2 - v^2$

---

## 2 A Thought Experiment

Let us consider a simple gedanken experiment where two light beams, originating from a single one, using beam splitter, are allowed to propagate in two opposite directions  $OA$  and  $OB$  (fig. 1) along closed linear paths in the lab frame. For convenience, we choose our coordinate system in such a way that the points  $A, O, B$  are on the  $x$ -axis.  $O$  is the midpoint of  $AB$  so that  $OA = OB = L$ . We shall take different situations in-

Hence the difference in arrival times between the counter-propagating light rays is exactly the same to eq. (8) as obtained in the Lab frame. However, one may notice that the above derivation does not give the time dilation effect. In his review article Post [6] argued that the time coordinate should transform as  $t' = \gamma t$  while switching over from Lab frame to stationary frame which leads to the time dilation effect.

A worthwhile point to be noted that the metric given in eq. (10) is derived from the Lab frame space time metric; it is the metric of the rotating frame according to a Lab frame observer. Though mathematically it is fine but the physical understanding of the effect from the standpoint of an observer attending the rotation remains difficult. When  $p = 0$ , i.e. the observer

Note: Bhadra's explanation

Invokes the lab frame, denies absolute but can't explain the PHYSICAL DISPLACEMENT WITHOUT changing  $c$ .



## 4 Discussion

We conclude that the origin of the Sagnac Delay or the phase difference in Sagnac or Sagnac-like experiments is the non-mid-point measurement of arrival times of counter-propagating waves leading to unequal path lengths traversed by the oppositely directed light rays in reaching the interferometer. It does not depend

In the proposed linear case there is a relative velocity between the detector and the reflectors and the distance between the detector and the reflectors continuously alters, unlike the Sagnac experiment where such distances always remain the same, at least in the lab frame. The gedanken original Sagnac kind experiment involving rotation also validates the non-mid-point measurement as the root cause of the Sagnac effect in the Lab frame.

Note: Unable to answer the Sagnac effect as a Relativistic as late as 2022.

---

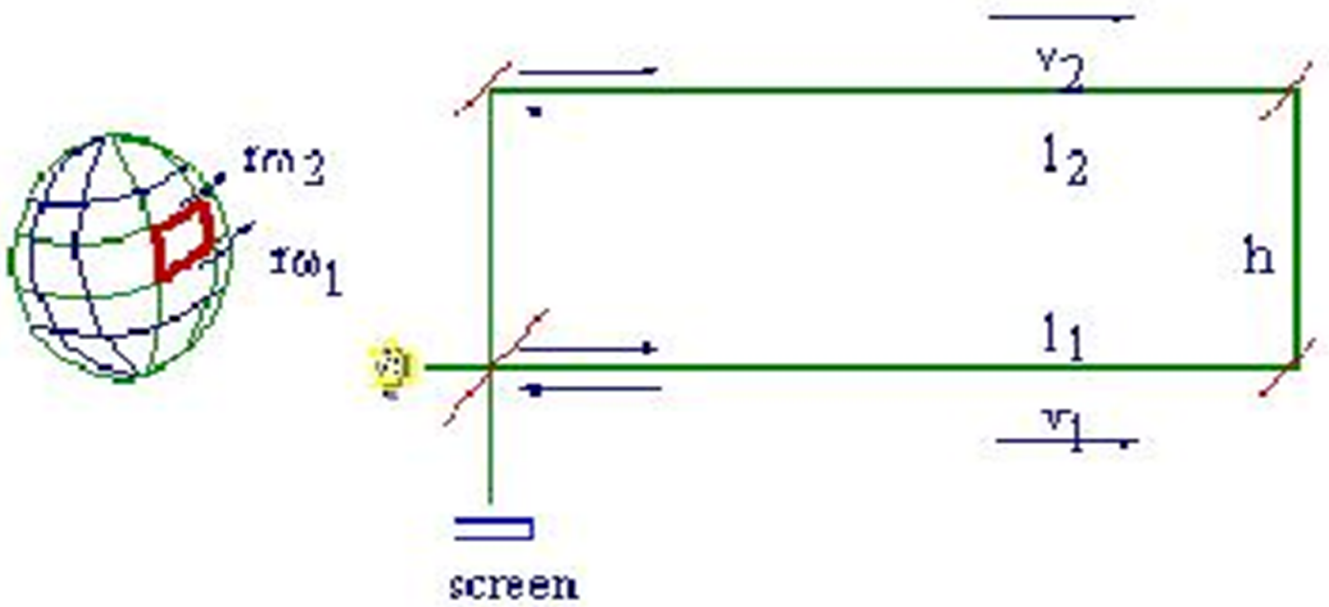

Note:

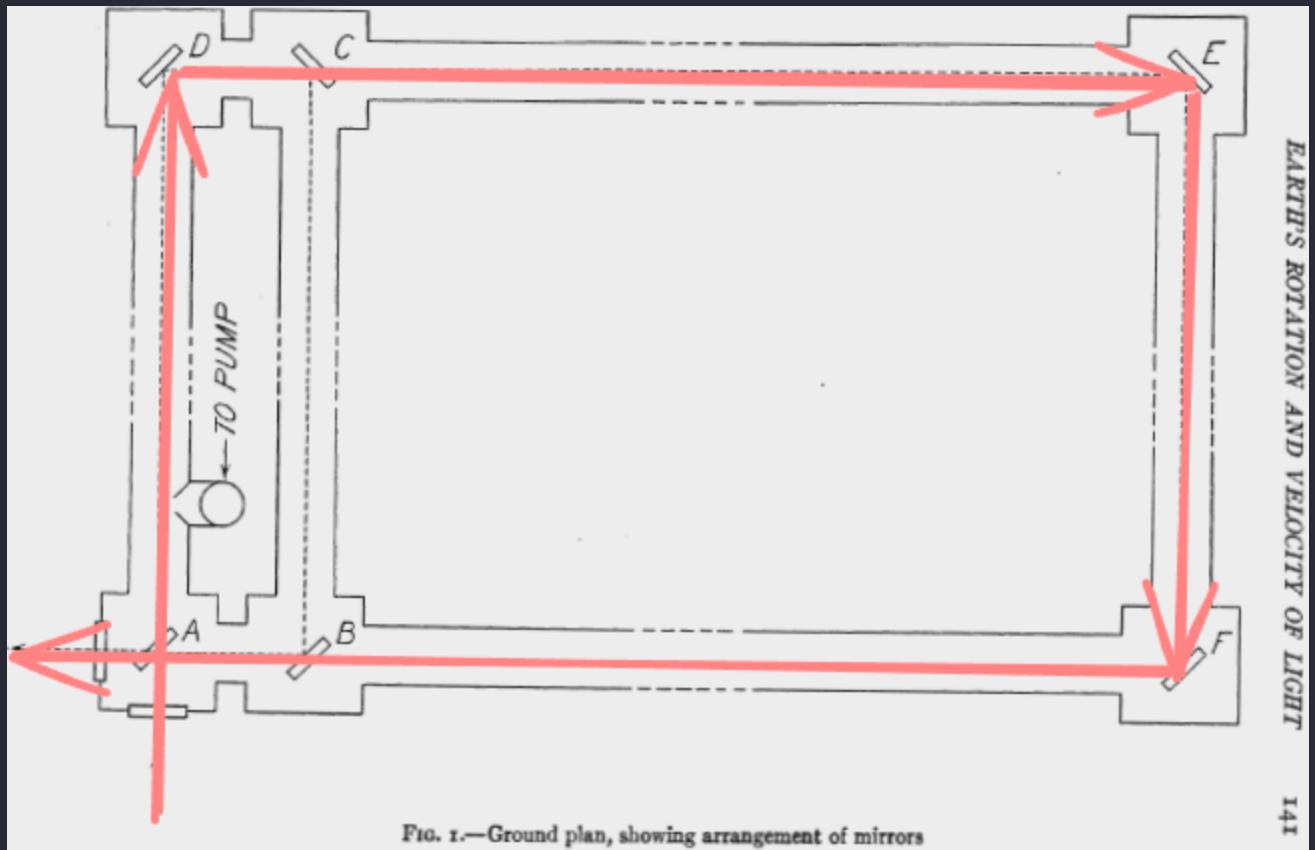

FIG. 1.—Ground plan, showing arrangement of mirrors

Note: First-order setup. A split CW and CCW beam complete the circuit that recombines at the start of the loop.

# THE EFFECT OF THE EARTH'S ROTATION ON THE VELOCITY OF LIGHT

## PART I

By A. A. MICHELSON

### ABSTRACT

*Theory of the effect of the rotation of the earth on the velocity of light as derived on the hypothesis of a fixed ether.*

*Historical Remarks.*—The theory was given originally in 1904. The experiment was undertaken at the urgent instance of Dr. L. Silberstein. A preliminary experiment at Mount Wilson in 1923 showed that it was necessary to resort to an exhausted pipeline.

In the *Philosophical Magazine*, (6) 8, 716, 1904, a plan was proposed for testing the effect of the earth's rotation on the velocity of light. The expression for the difference in path between two interfering pencils, one of which travels in a clockwise, and the other in a counterclockwise direction, may be deduced on the hypothesis of a fixed ether as follows:

If  $l_1$  is the length of path at latitude  $\phi_1$  and  $l_2$  that at latitude  $\phi_2$ ,  $v_1$  and  $v_2$  the corresponding linear velocities of the earth's rotation, and  $V$  the velocity of light, the difference in time required for the two pencils to return to the starting-point will be

$$T = \frac{2 l_2 v_2}{V^2 - v_2^2} - \frac{2 l_1 v_1}{V^2 - v_1^2}$$

137

Note:

difference in the measured displacements.

The calculated value of the displacement on the assumption of a stationary ether as well as in accordance with relativity is

$$\Delta = \frac{4A \omega \sin \phi}{\lambda V}$$

where  $\Delta$  is the displacement in fringes,  $A$  the area in square kilometers,  $\phi$  the latitude ( $41^\circ 46'$ ),  $V$  the velocity of light,  $\omega$  the angular velocity of the earth, and  $\lambda$  the effective wave-length of the light used. Measurements were made in the laboratory, comparing the

Note: Here we have a first-order effect (velocity) being measured in a second-order experiment.

Here we have a problem this calculation is based on absolute space. Which is invoking a distance change in the propagation inside of the pipes. If a distance changed is invoked, then the N/S pipes must also produce a fringe pattern.

They produce no such fringe pattern. Only a fringe in the E/W and W/E direction is present. The explanation given is stated to be consistent with an static ether framework. i.e. Relativistic derivation must also N/S variance since the N/S mirrors will also be in a physically different location than when the experiment starts.

Further, the actual relativistic derivation is based not on absolute space, but that light is being dragged by Earth's electromagnetic field to get a speed boost. It is also claimed by the Relativists of the time that the static ether prediction was that MPG would give a zero fringe reading because there would rotating ether trapped inside the tubes that would cancel out the speed boost.

Again, this preservation of distance traveled does not produce fringes.

IV - Orientation and medium in the tubes

DV - Fringe

Result: A fringe shift proportional to the angular velocity of  $15^\circ/\text{h}$  was measured.

This satisfies the space effect condition of our aether hypothesis.

---



Note: Dayton Miller - 1902 - 1933

IV - Orientation and time of day the measurements were taken, altitude

DV - Fringe

First-order Effect - periodicity that matches sidereal time

Second-order Measurement: orthogonal interferometer

Summary over 30 years of experiments, Miller honed the interferometer to isolate the effects he was measuring. After rigorous trial and error and controlled experiments, Miller discovered through analysis in the data that he was measuring sidereal fluctuations with in the fringe patterns. Implying  $c$  changes throughout the day and such that it correspond with sidereal time. To the point where the fringes were found to reach their minimum and maximum dimensions on the equinoxes.

---

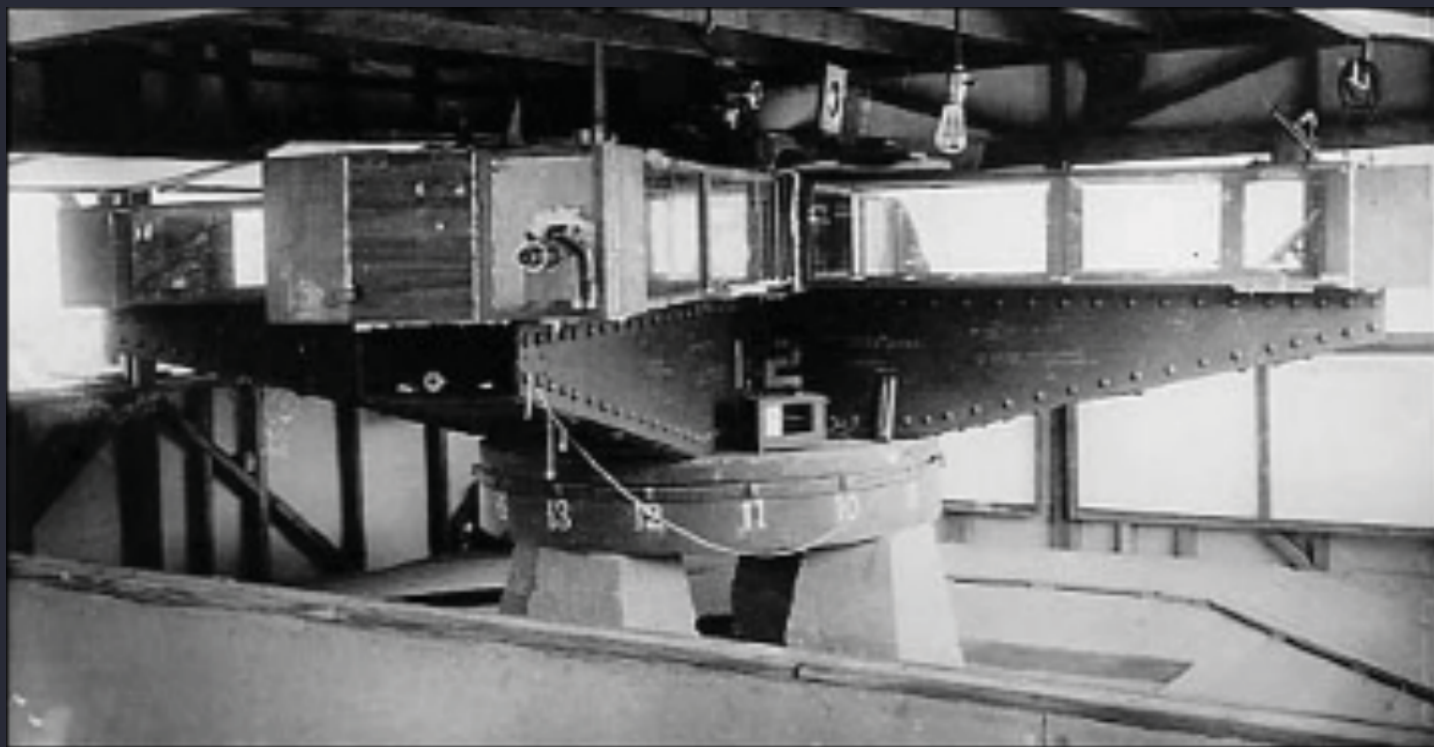

Note:

**Figure 1. Dayton Miller's light-beam interferometer**, at 4.3 meters across, was the largest and most sensitive of this type of apparatus ever constructed, with a mirror-reflected roundtrip light-beam path of 64 meters. It was used in a definitive set of ether-drift experiments on Mt. Wilson, 1925–1926. Protective insulation is removed in this photograph, and windows were present all around the shelter at the level of the interferometer light-path (see below).

---

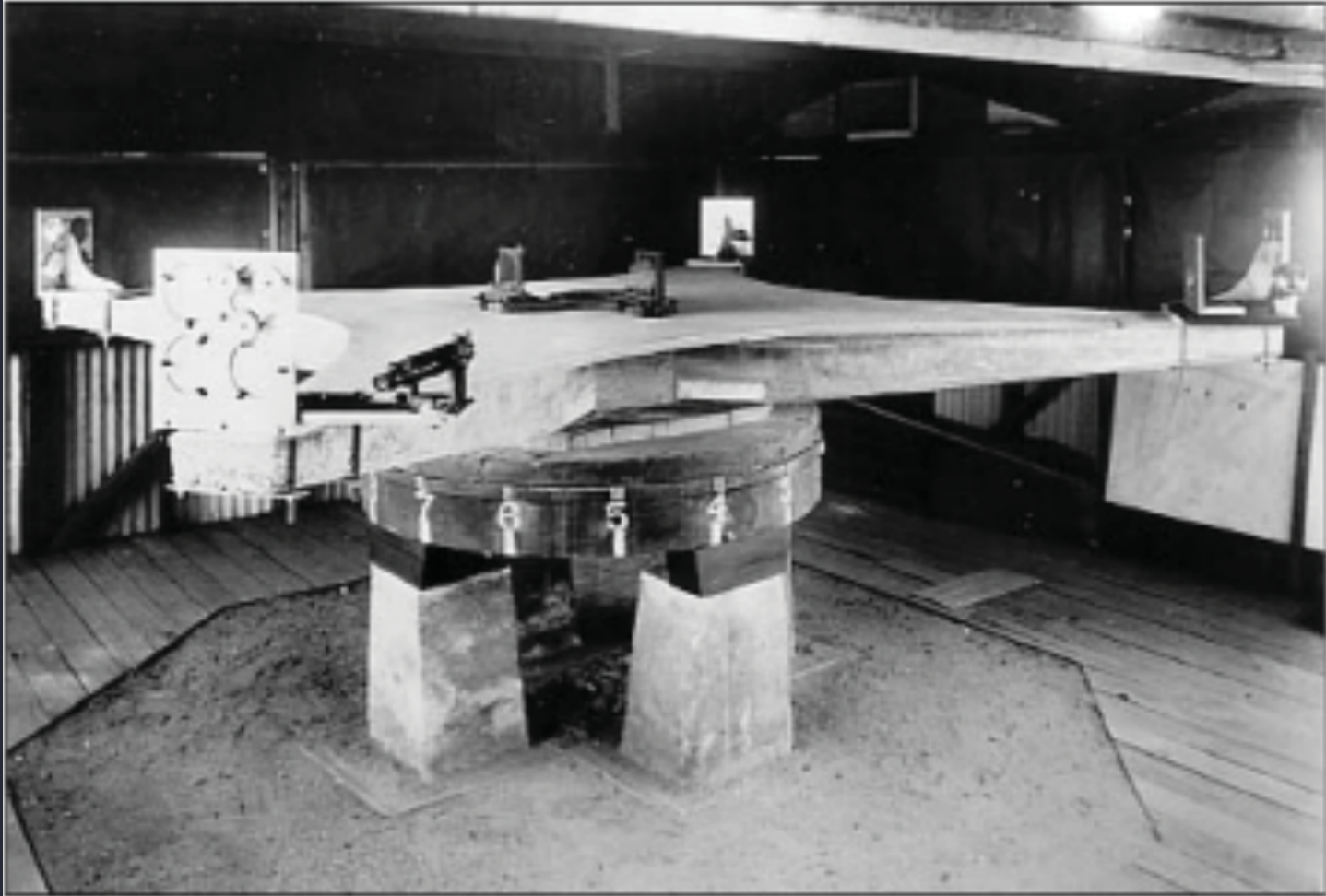

Note:

**Figure 7. Miller's Control Experiments.** A concrete platform supports the mirrors and optics of the interferometer inside a small shelter on the grounds at the Case School.



Note: Optimal housing; open; free flow; thermally insulated without using dielectric material or Fermi surfaces

---



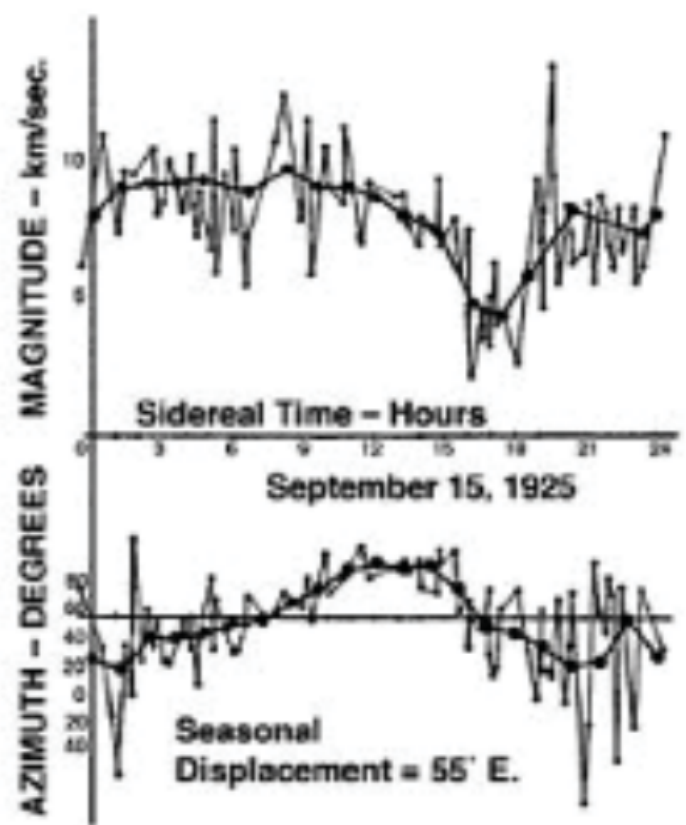
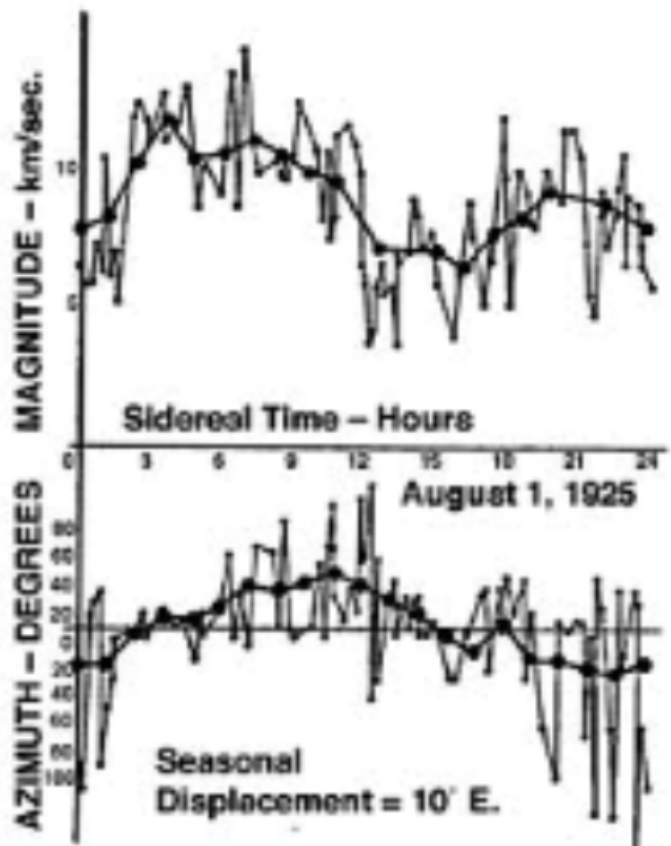
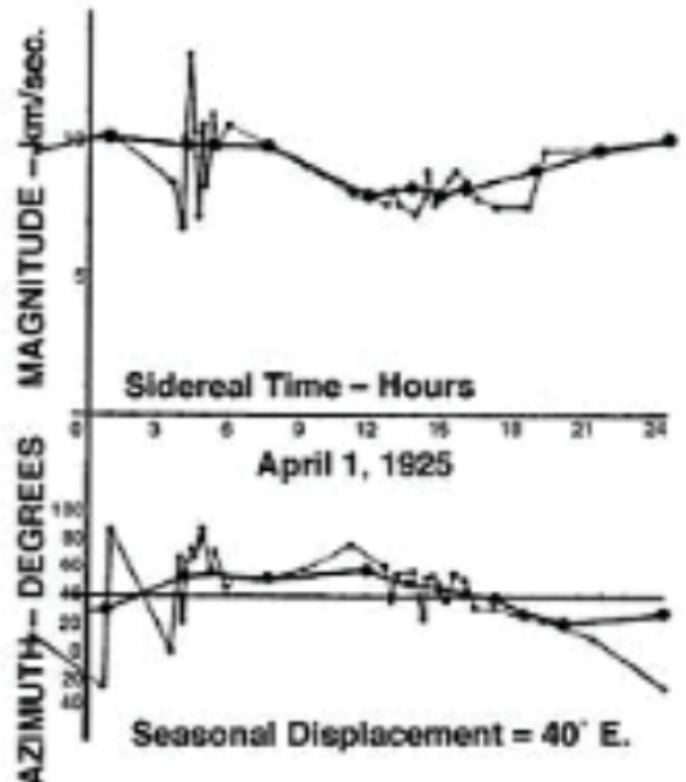
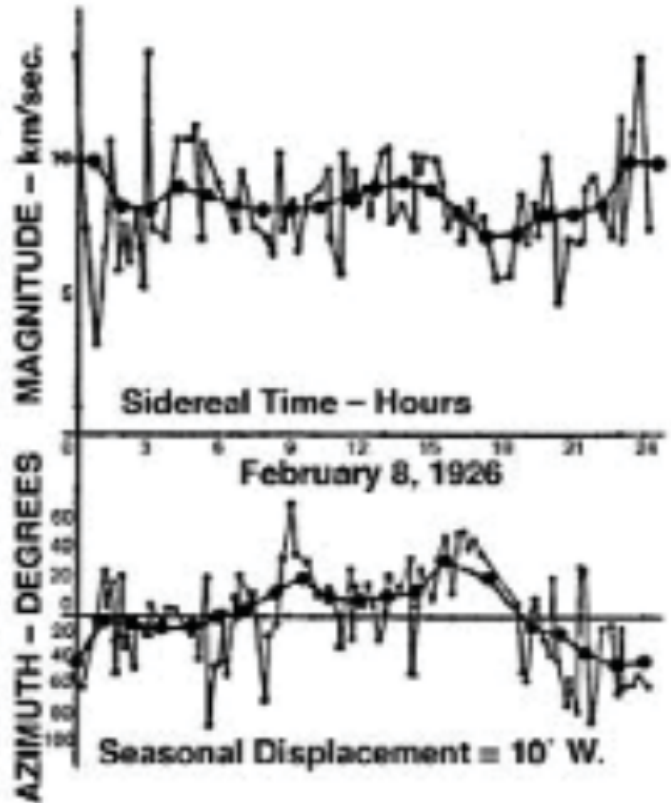

Note: A periodicity within the epochs where a minimum and maximum dimensions on the fringe is shown. Indicating that SoL changes by that mount.

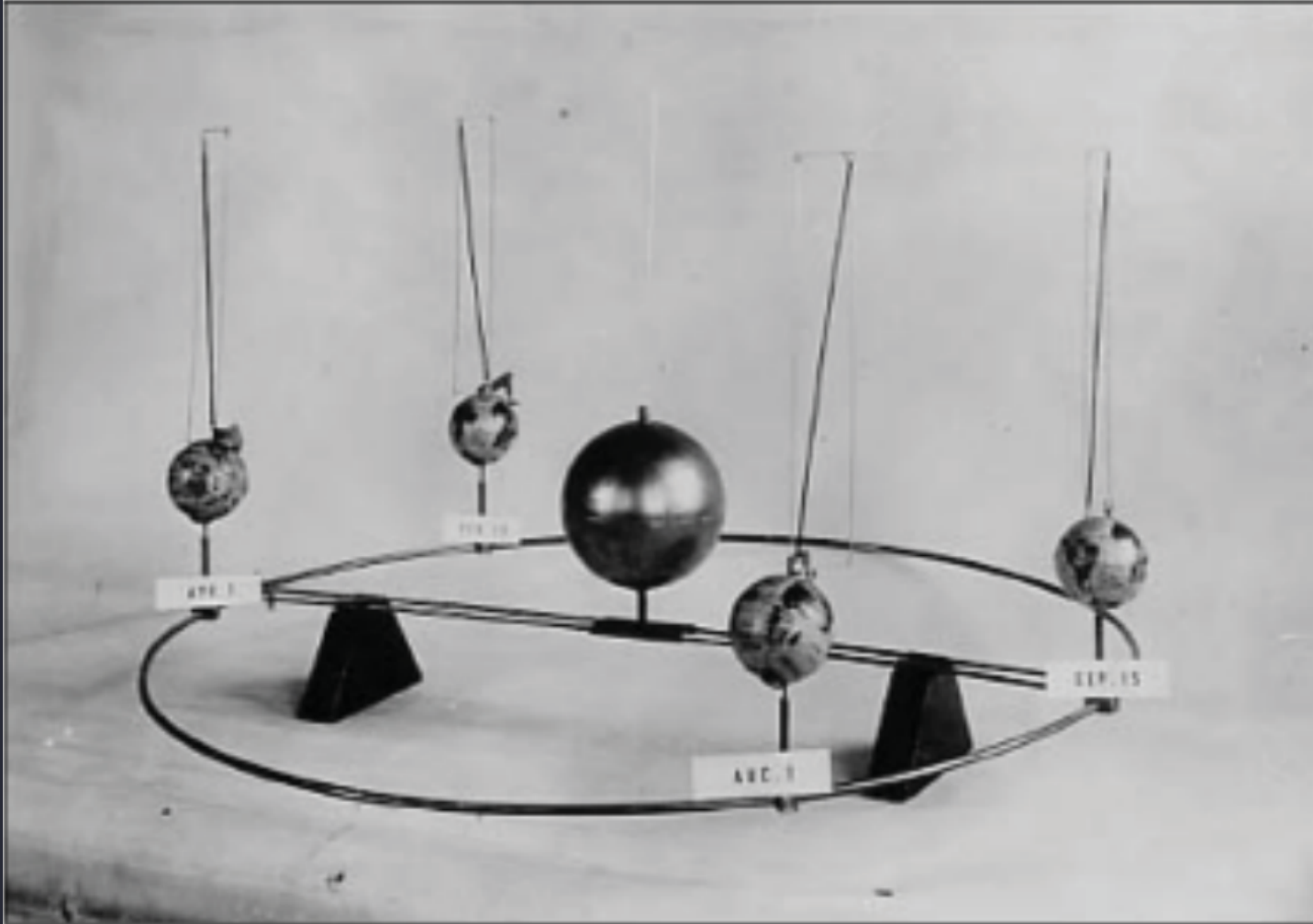

Note: Model of what Miller measured, assuming the ecliptic plane is caused due to Earth being axially tilted and the magnitude of the fringes correlating with sidereal time.

Miller was Copernican, so interpretation of the data was that the Earth's velocity around the sun had been measured, just at lesser speeds due to some unknown mechanism. After 30 years of experiments and research, it was obvious Miller's work couldn't be refuted. Towards the end of his career, he was isolated and ignored.

While Dayton Clarence Miller was alive, no man could refute his work. It wasn't he passed away did the hit pieces come trickling down.

Miller wasn't a punk though. He knew what he was measuring and he made it very clear to separate his second-order interpretation of the measurements and not forget the importance of the first-order effect measured; the ether wind.

---

range.

The purpose of this work is to experimentally verify, in the optical wave range, the hypothesis of the existence in nature of the ether, a material medium responsible for the propagation of electromagnetic waves. The second goal of this work is to measure the kinematic viscosity of the ether. Thus, the present work is a logical continuation of the studies carried out in the radio wave range. In order to achieve the goals of the work, the following basic tasks should be solved.

Note: Yuri Galaev; purpose; confirm Miller's work, measure kinematic viscosity of the ether.

---

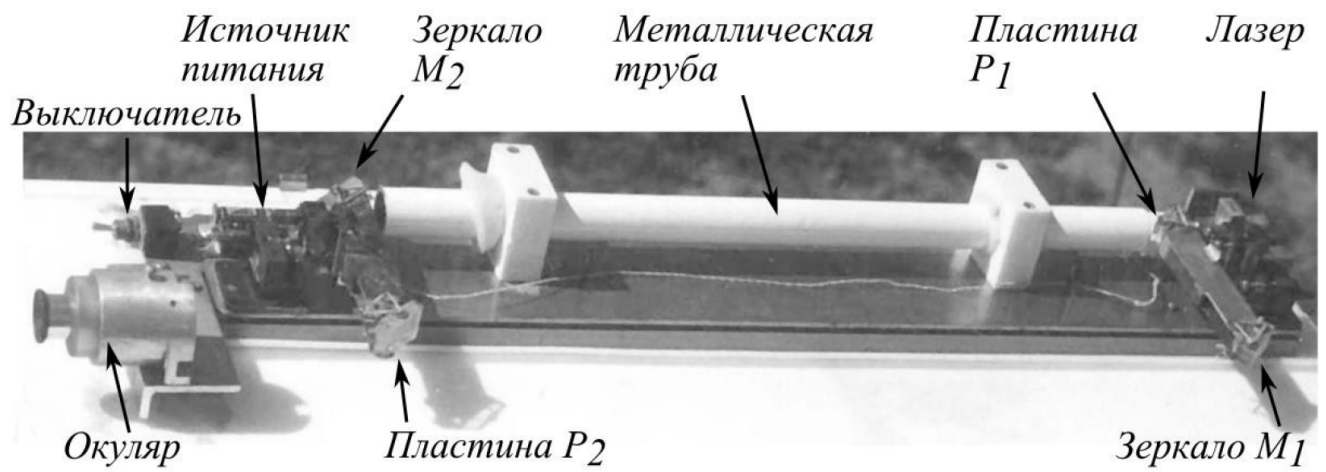
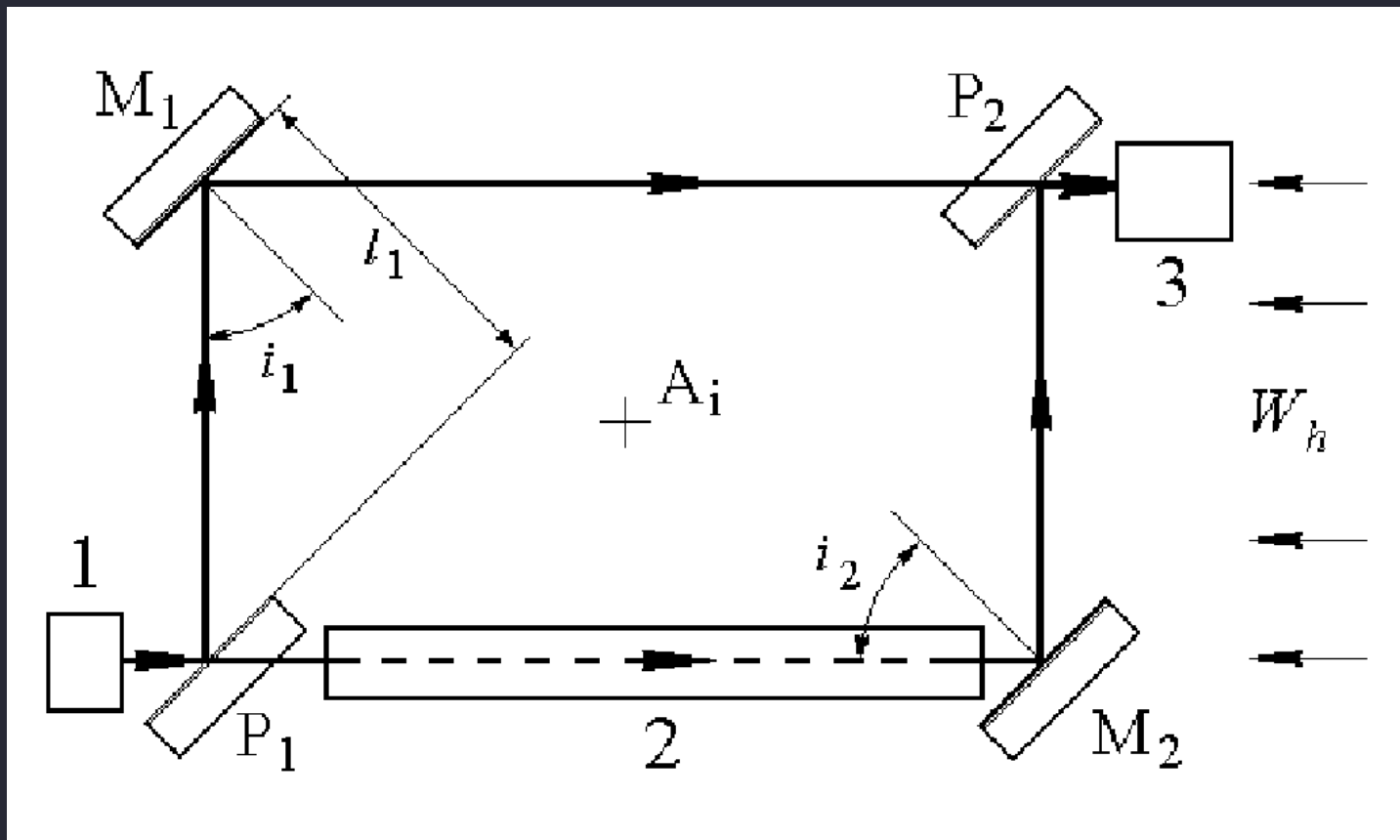

Fig. 21.6. Photograph of the interferometer [23]

Note: Galaev, [Hydroaerodynamic](#)

Using a closed loop circuit, [Galaev](#) took measurements of the ether wind and how it would respond to [Fermi surfaces](#) and [dielectric insulators](#).



Note:

Placed a tube part into a gas stream in such a way that the direct tube axis was perpendicular to the stream velocity vector, and then turning the tube so that the velocity vector of the ether wind was directed along the tube axis.

Measured how fast the bands of the interference pattern would offset due to the ether drift stream in a tube. This allowed him to determine the values of the ether drift velocity and the ether kinematic viscosity.

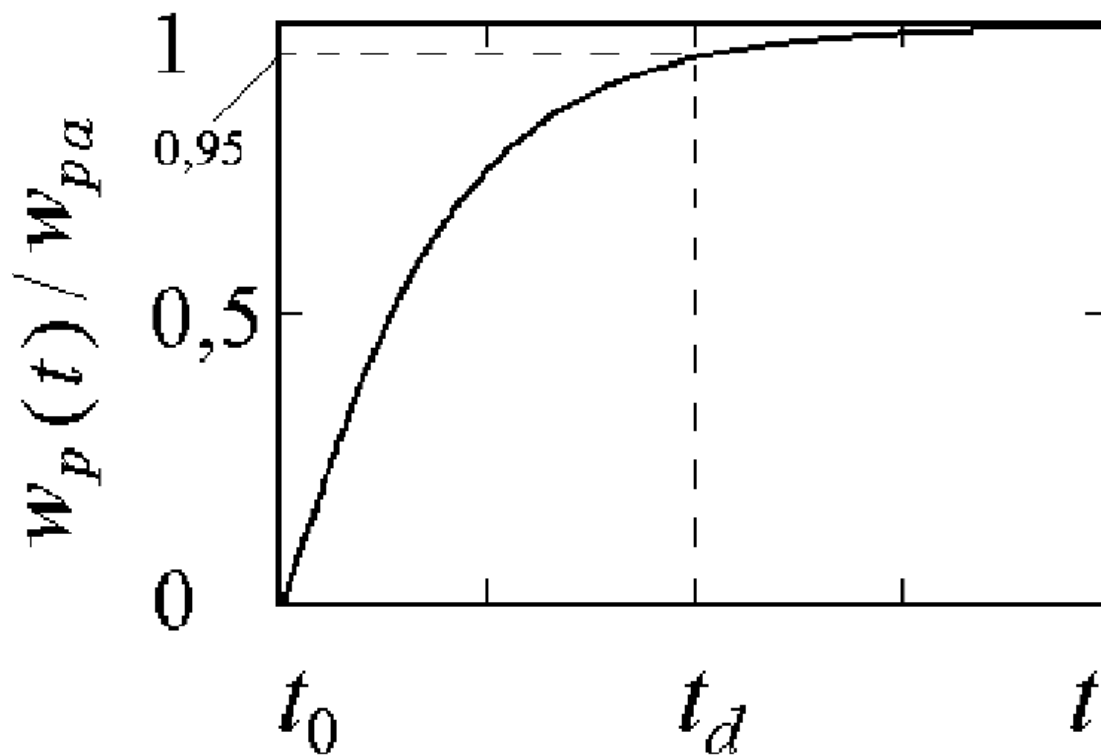

Figure 2: Variation in time of fluid movement velocity in a tube

Note:

In the graph above, the transition from turbulent to laminar flow occurred when the threshold reached 0.95, signifying the settling and steadying of the gas flow.

Galaev utilized wavebands to discern between laminar and turbulent flow by observing the interference fringes produced by the gas-like ether in the tube. Laminar flow resulted in consistent and predictable fringes, while turbulent flow exhibited irregular and fluctuating patterns.

By relating these patterns to [hydroaerodynamic](#) equations and mapping out the relationship when the wavebands were aligned with or perpendicular to the ether wind, Galaev effectively measured the kinematic viscosity, the material background medium. necessary for electromagnetic propagation.

This satisfies the hydrodynamic effect. The material medium interacts with material objects like a fluid or gas would when it becomes turbulent and laminar. Additionally, to test the viscosity of a fluid in motion, there will also be a motion gradient within the medium.

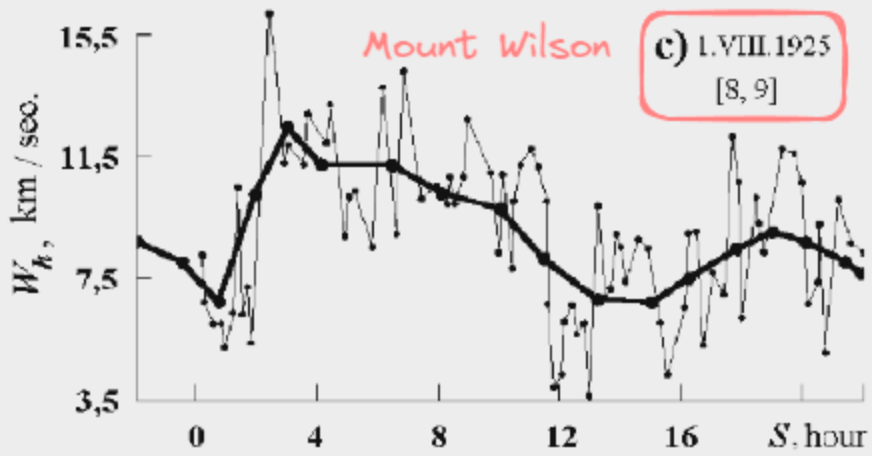
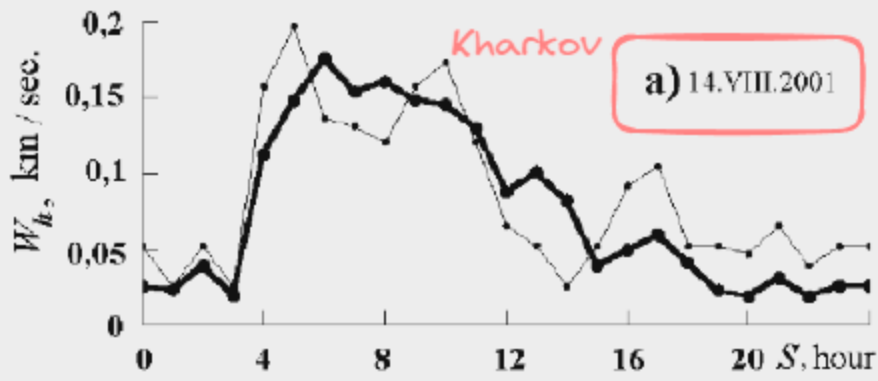

The dependencies  $\overline{W_h(S)}$  have the forms of periodically changed values with the periods equal to a stellar day, that can be explained by a space (galactic) origin of the ether drift. In the work, the observed bands offset direction of an interference pattern corresponded to the ether drift northern direction at measurement implementation. Hence, the results of the work do not contradict the experiment results [1-3], [7-9], [10] and imaginations of the works [4-6] about the northern position of the ether drift apex, that demonstrate the reproduced result nature of the ether drift effects measurement in different experiments, performed with different measuring methods application.

Note:

Miller's results reproduced

The observed daily fluctuations in the ether drift velocity align with sidereal time and exhibit minimum and maximum dimensions corresponding to sidereal time, matching Miller's findings.

First-order effect,

First-order Measurement,

First-order mathematical analysis

Able to draw cause and effect relationships with the math he's using to describe the effects. i.e. the turbulent and laminar flow of a material medium.

---

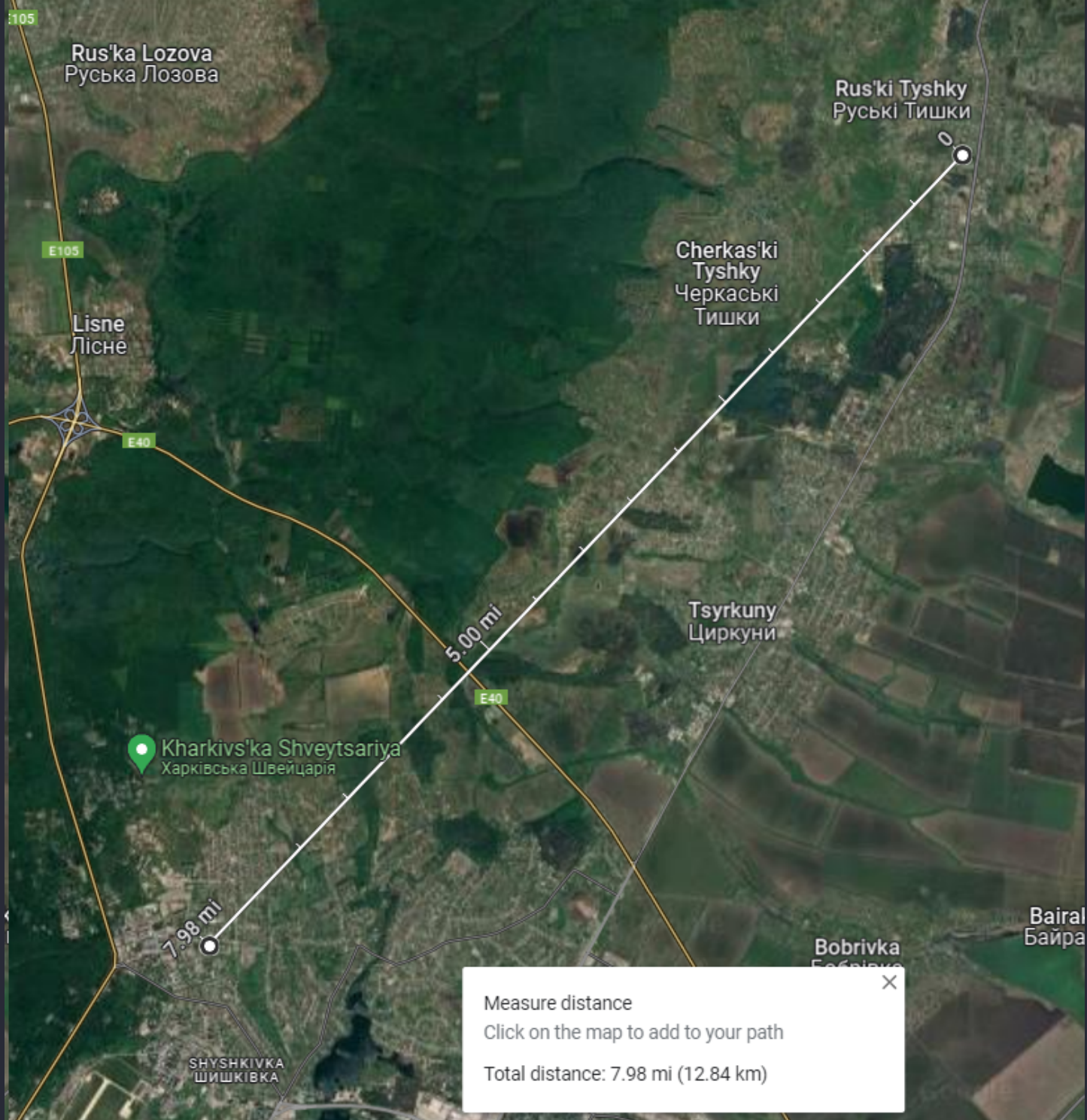

Note: Galaev 2001, [Altitude effect](#) / [Height effect](#) satisfied in a new experiment by Galaev using millimeter radiowaves.

---

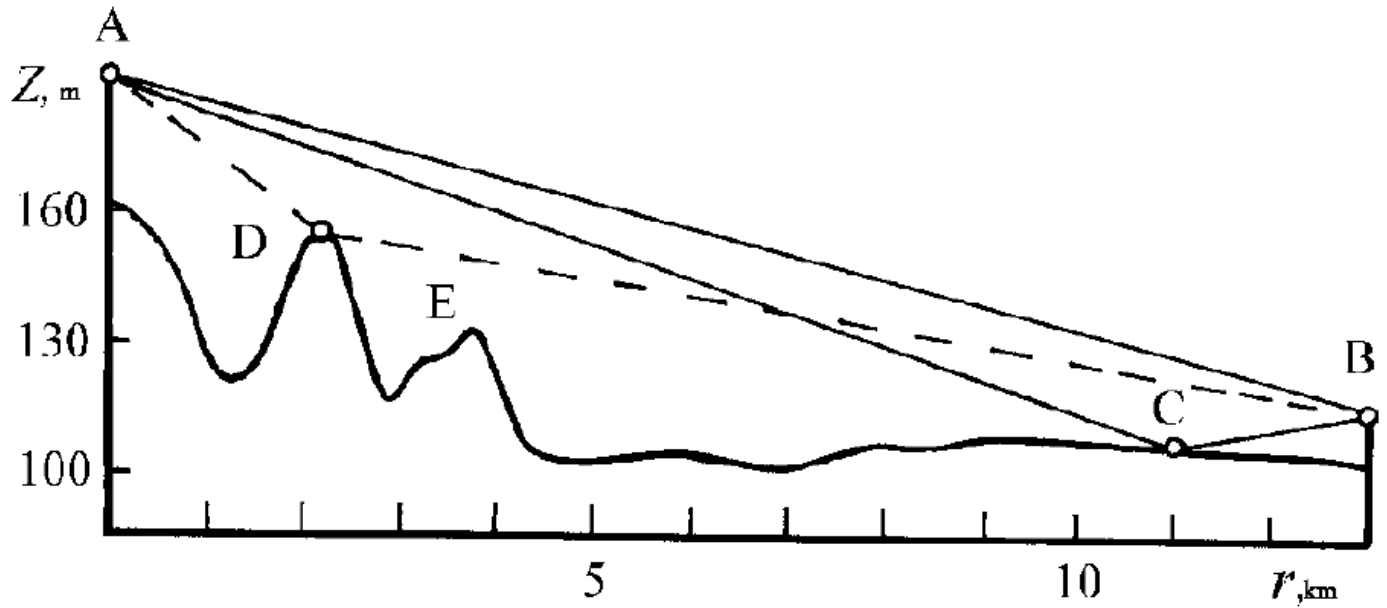
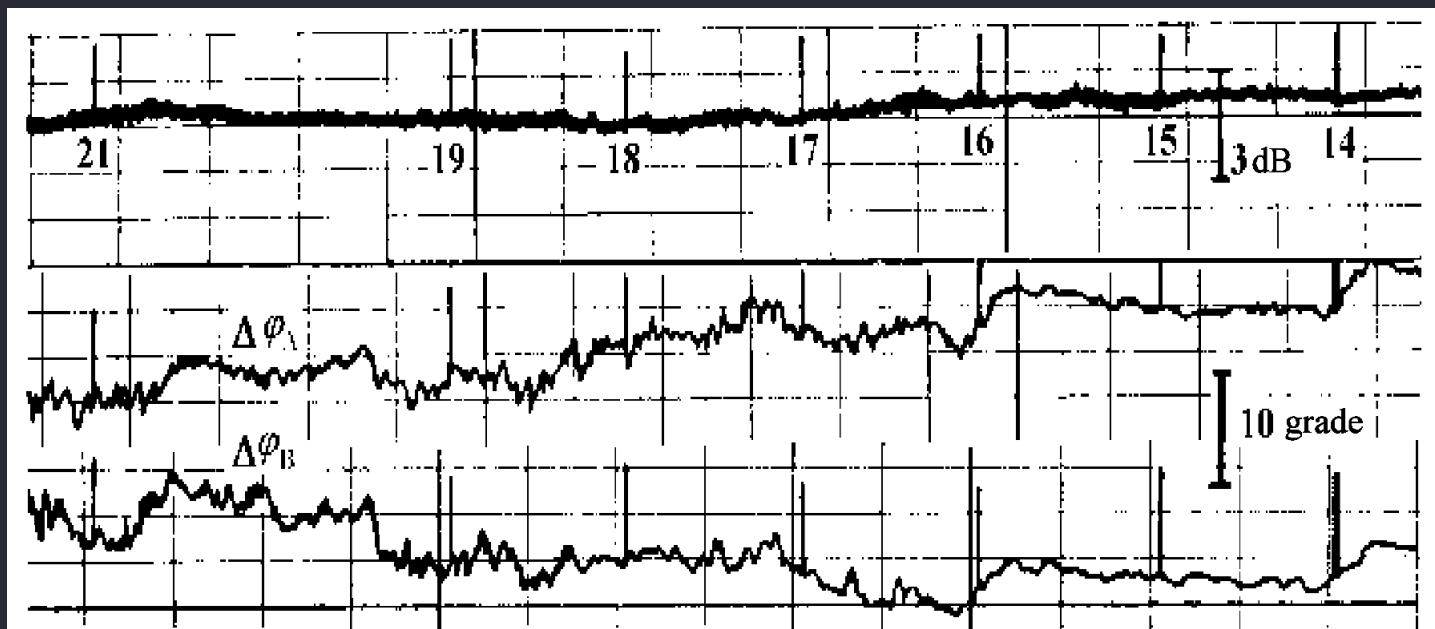

Figure 2: The experimental radiolink profile



Note: Symmetrical periodicity in the East -> West and West -> East readings  
 the gradient value of the ethereal wind speed (gWrK) at 6.4 m/sec based on the high-altitude gradient relation, which matched Cleveland's data and scales up to match the gradient at Mount Wilson as well



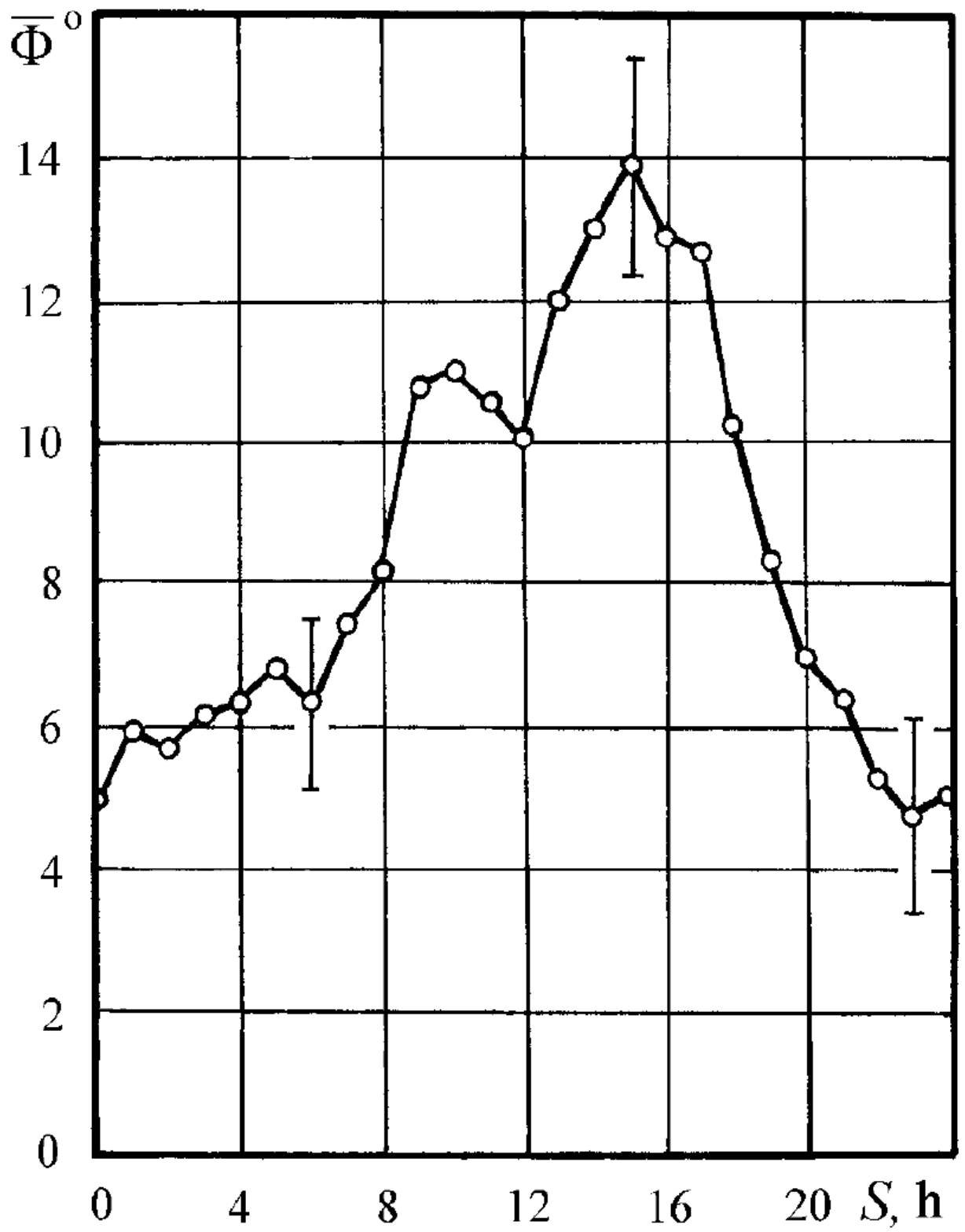

Figure 7: Mean diurnal variation of the measured value

Note: sidereal fluctuation reaching minimum and maximum dimensions within diurnal time. Showing that the cause of the fluctuation is related to sidereal events.

Table 3: The ethereal wind parameters

1	2	3	4	5	6
$\bar{\Phi}$ , grade	$g_{WK}$ , m/s·m	$W_K$ , m/s	$W_{MK}$ , m/s	$W_M$ , m/s [5]	$W_M$ , m/s [11]
14	$\frac{8,63}{6,22}$ ; (9,05)	$\frac{1414}{1019}$	$\frac{8490}{6124}$	9000	6000

Note:

1. ( $\bar{\Phi}$ , grade): Represents the measurement result  $\bar{\Phi}$  (S) max in grades, as shown from the statistical processing of the measurement results.
2. Represents the calculated value  $g_{WK}$  obtained from expressions (37), (41).
3. Represents the calculated value  $W_K$ , the horizontal component of the ethereal wind speed, derived from the executed estimations and calculations. (42)
4. Represents the calculated value  $W_{MK}$ , the maximal ethereal wind speed value adapted to the observatory Mount Wilson location.
5. Represents the maximal ethereal wind speed value obtained by Miller at the observatory Mount Wilson in April, August, and September 1925.
6. Represents the maximal ethereal wind speed value measured in the experiment at the observatory Mount Wilson in 1929, corresponding to the findings of a previous study (11)

$g_{WK}$  represents the anticipated ethereal wind velocity gradient value in Kharkov,

$W_K$  represents the horizontal component of ethereal wind speed at a specific geographic latitude and altitude.

$W_M$  = Mount Wilson

Note:

First-order effect: Velocity gradient measured that increases with altitude

First-order Measurement: The Radiolink setup was configured to take 1 one-way measurements from link A to B and B to A.

IV: Geographic latitude, altitude, time and orientation

DV: fringe produced by the velocity gradient

First-order mathematical analysis and used equations that make dynamic predictions.

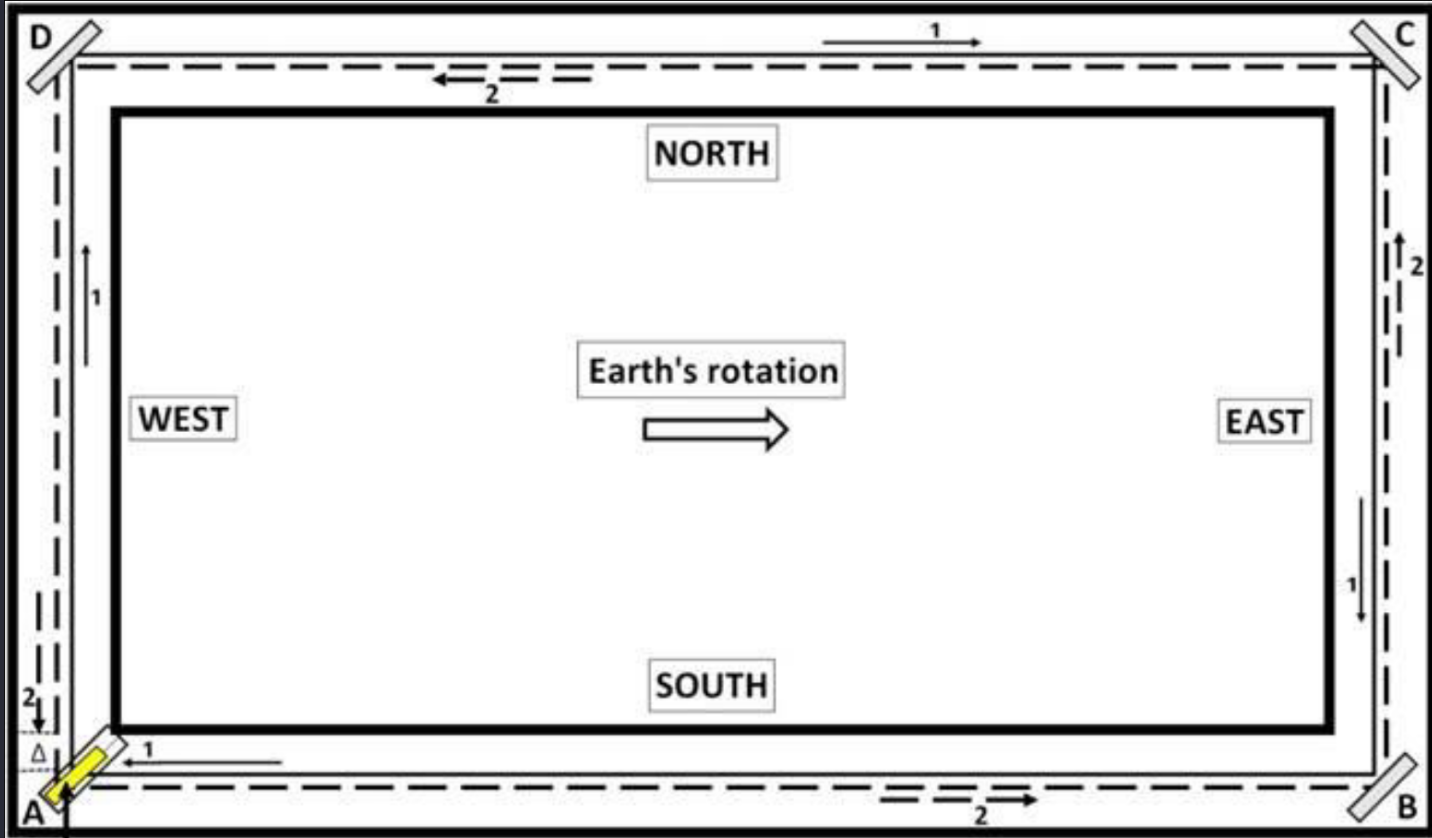

Note: [Michelson-Gale-Pearson](#)

Get the angular rotation specs th at define MGP as an inertial frame. How much more inertial do you need? The test suggest the speed going east vs west is different.

Sharlanov, G. V. (2015). "The Complete Set of Proofs for the Invalidity of the Special Theory of Relativity."

Ether Wind Model: Intact

Relativity: Shambles

Heliocentrism: Untenable

Stationary Earth: Tenable.

Note:

Recap

# End